

Heat-Kit System Modular Contraflow Masonry Heater Core

Assembly Manual

HK-22fo

22" Firebox with Front or Rear Bake Oven

Updated on July 17, 2024



HeatKit Hearth Systems
Plamondon, Alberta
(780)9537188
compassbrickandstone@gmail.com

HeatKit core assembly manual

Setting Firebricks

Firebricks are laid up with clay air setting refractory mortar with thin joints. Only enough clay needs to be used to completely fill the joint. No joint thickness needs to be built up - you are only filling in gaps and irregularities between the bricks. Although masons are used to trowelling firebricks, the best joints are obtained by dipping the bricks into mortar that has been thinned to the right consistency. It looks messy, but the cleanup is easy later with a sponge.

The that comes with the heater core kit is at trowelling consistency. For dipping, you will need to thin it with water. A drill powered drywall mud mixer works well for this. You can tell if the Sairset has the right consistency by floating a firebrick in it. It will sink about half way. We like to dip the bricks and also keep a margin trowel (small rectangular trowel) handy for trowelling.

You can find an assembly video that shows the laying of the firebrick on the Heatkit website at:

<https://vimeo.com/211742460>

Assembling the Firebox

The firebox is laid up from standard firebricks. Standard firebricks are 4 ½" wide by 9" long by 2 ¼" thick. The thickness will vary between 2 ¼" and 2 ½" depending on the supplier. Since the Heat-Kit is designed around the standard firebrick module, it is important to check the width and length of your bricks beforehand, to avoid having to make modifications to the assembly procedure. If you have 2 ½" bricks, you may need a few extra cuts on the bottom two courses underneath the firebox.

The firebox consists of two shells of firebricks set on edge. This allows the inner shell to be a field replaceable firebox liner. The firebrick installation sequence has been numbered. By following this order, you maximize the ability to "bury" odd lengths where they don't show and reduce the amount of precise cutting that you have to do. Note that full contact between inner and outer shell is not required at the inside corners. Where convenient, a little play right at the corner provides some expansion room for the liner.

Material List (in addition to core components)

200	Standard Firebricks 4.5"x9"x2.5" (2.5" dimension may vary. Important: The 4.5" and 9" dimensions are important)
7	Firebrick "Splits" 4.5"x9"x1.25"
1 bag	"Mortar Mix" (ie., premixed with sand, as opposed to "Masonry Cement", which requires mason's sand)

Concrete tie wire

Assembling the Bottom End

The bottom end of a contraflow heater is the most complicated part of the whole job. The two downdraft channels connect here, underneath the firebox. As well, the chimney connection and the cleanout openings for the particular installation need to be determined and located here.

We've removed as much of this complication as possible with the Heat-Kit system. The insulated base slab allows you to do a dry layout first and make sure that everything is located properly in relation to the chimney and the slab. As well, our thinwall refractory castings simplify the job of making the necessary cutouts with a portable masonry saw or a skilsaw.

If you take a little extra time at this stage, particularly with the layout, you'll avoid problems later on.

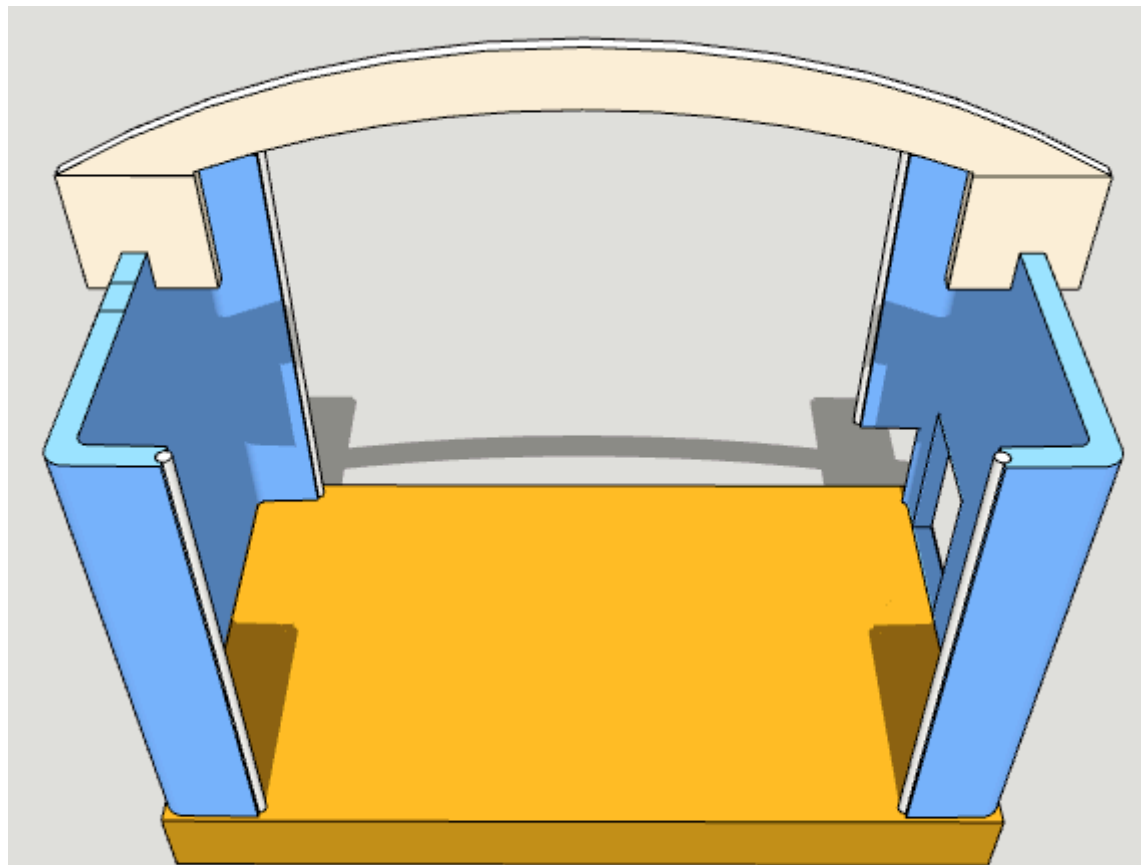

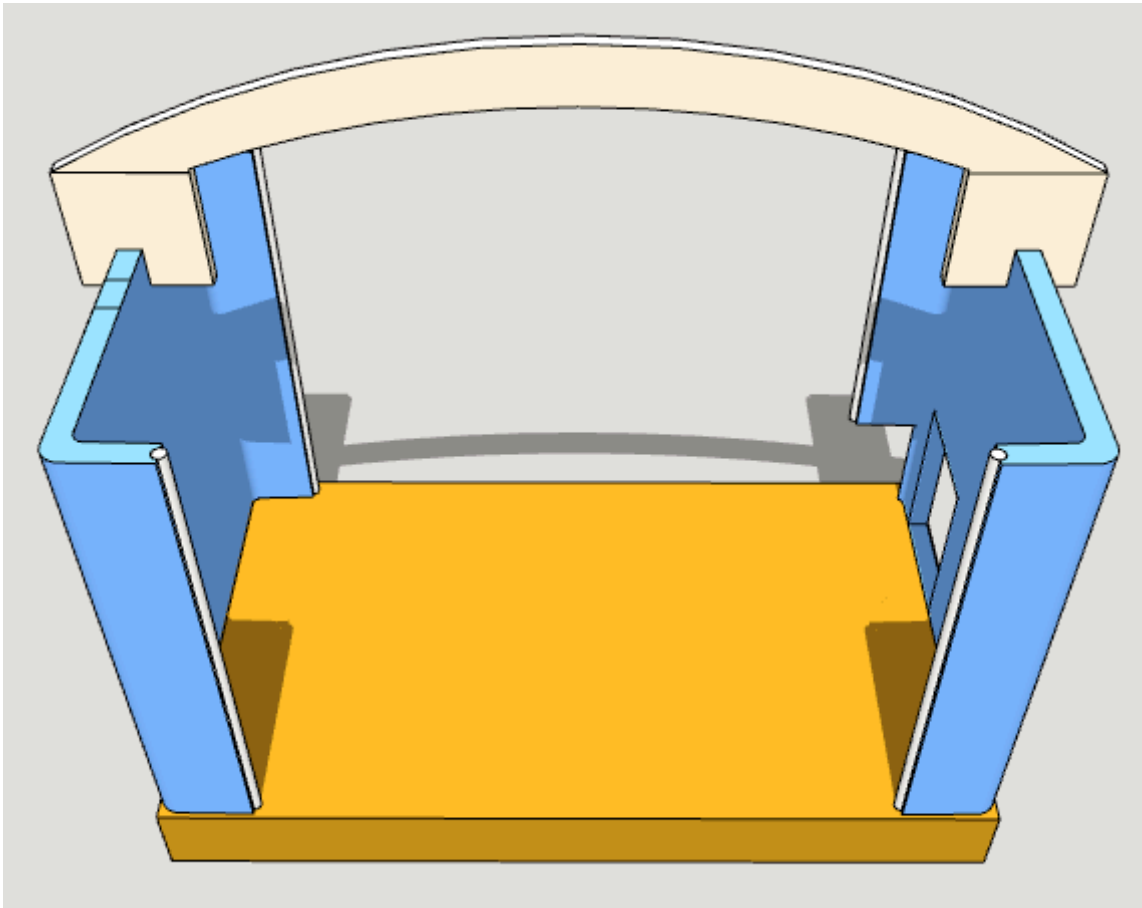

Position insulating base slab dry to determine layout for heater and chimney.

Mark final position at corners with a pencil.

Set insulating base slab in a 1/2" mortar bed, and level.

Determine location of chimney connection and location of 2 cleanouts, one for each bottom channel. In the illustration above, a 7" x 11" cutout is shown in the right channel, towards the back of the long side. Shown next to it is a cutout for a 5.5" x 5.5" cleanout that will be in the facing.

The left side also requires a cleanout at the base (not shown).

Mark clean out cuts on the base channels. Mark chimney connection on base channel.

Cut appropriate holes for chimney connection and for clean outs.

Set base channels dry. Use the plywood spacer to stabilize the channels as shown. Bottom seam will be sealed later by mortar slush between channels and facing.

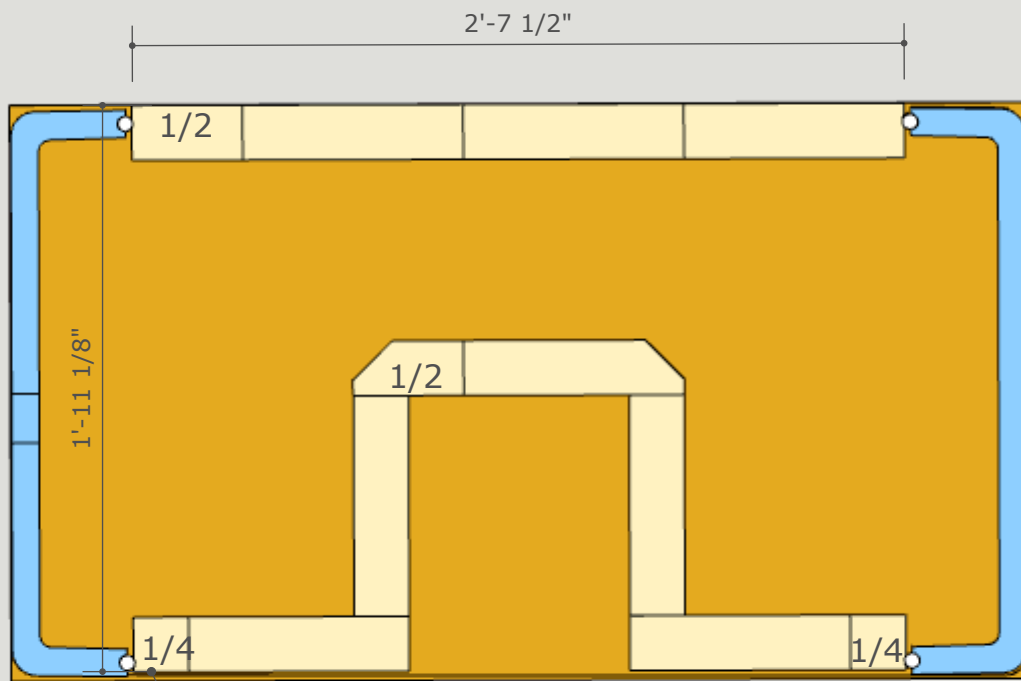

If firebricks are 2-1/4" thick, use 1/4 brick (2-1/4")
 If firebricks are 2-1/2" thick, use 2" brick

Brick Cuts:

For firebricks standard sizes are:

- full ---- 9"
- 3/4 ---- 6-3/4"
- half ---- 4-1/2"
- 1/4 ---- 2-1/4"

Build connecting channel, using refractory mortar.

If there is a rear chimney, leave opening and span with flat bar supplied. Notch bricks to accept flat bars, thus allowing you to maintain thin joints.

Firebrick shiners at the rear are flush with outside of slab.

(Note: "shiner" = brick set on edge)

Outside-to-outside on the firebricks (front-to-back) is 1-11 1/8" as shown.

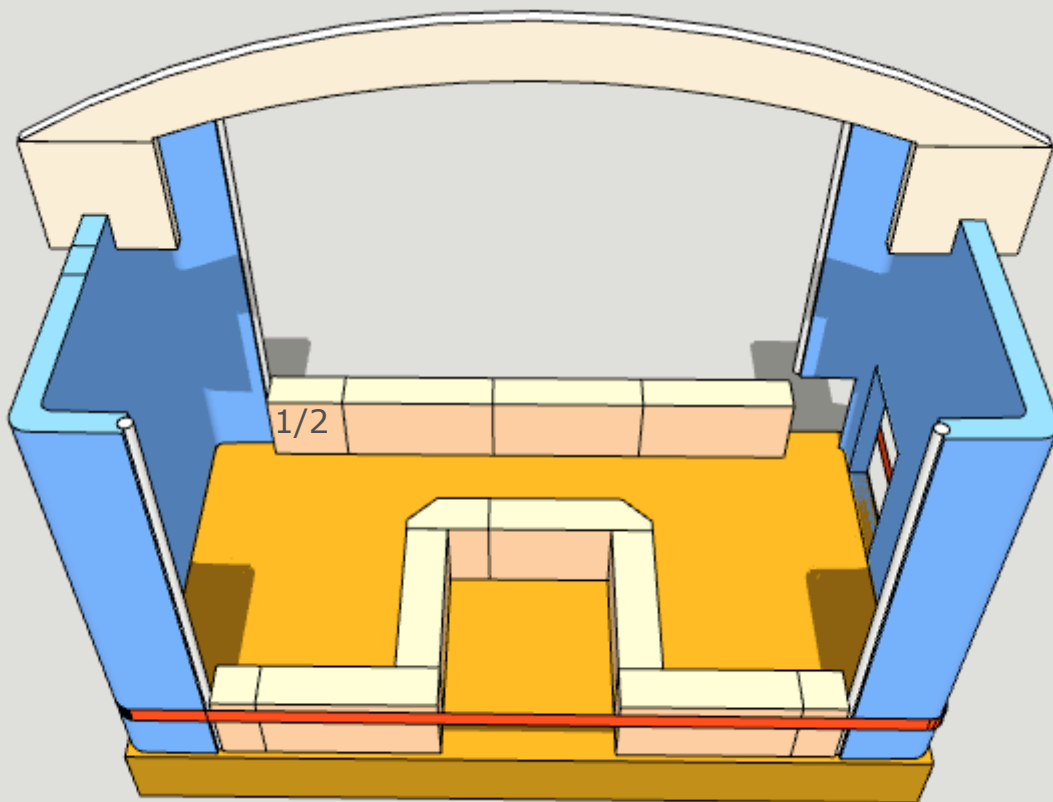

Once first course is set, install velcro strap (supplied with core kit) to stabilize bottom.

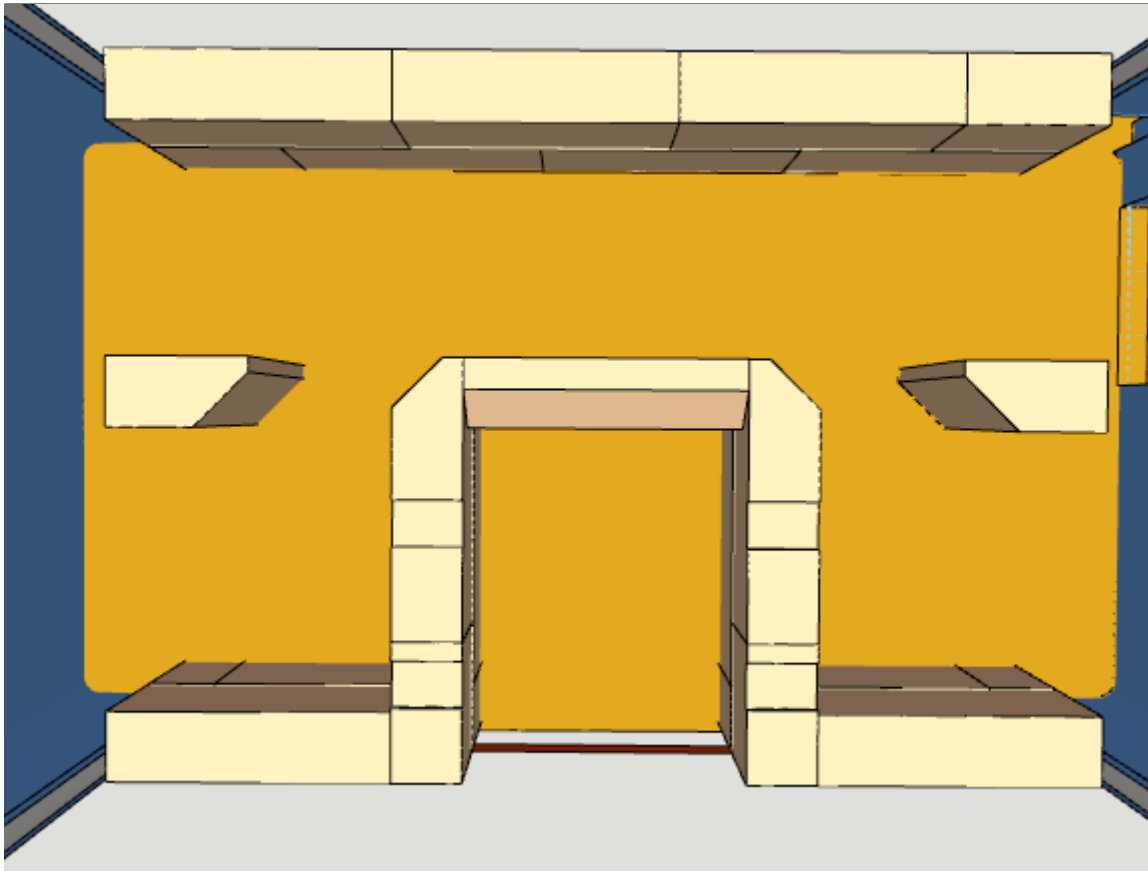

Second course.
Refer to isometric views on next page.

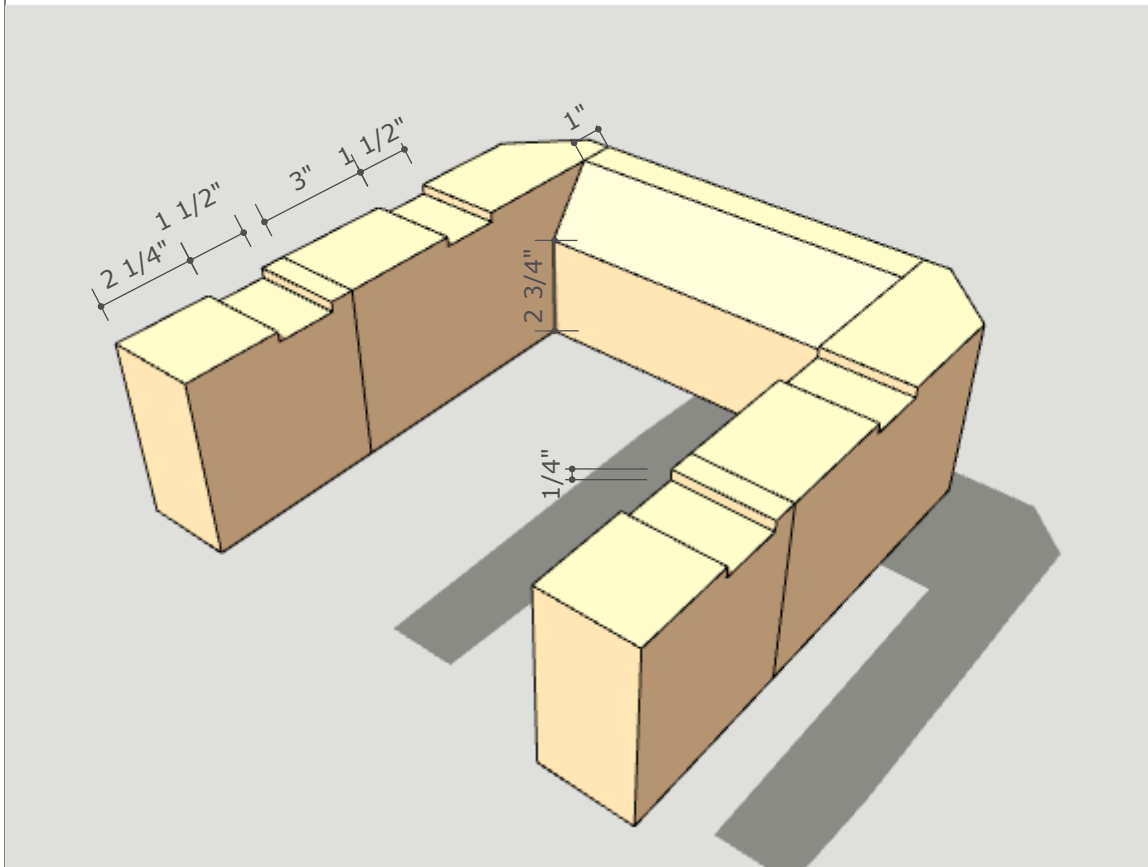

Cut 1/4" deep notches for flat bars as shown.

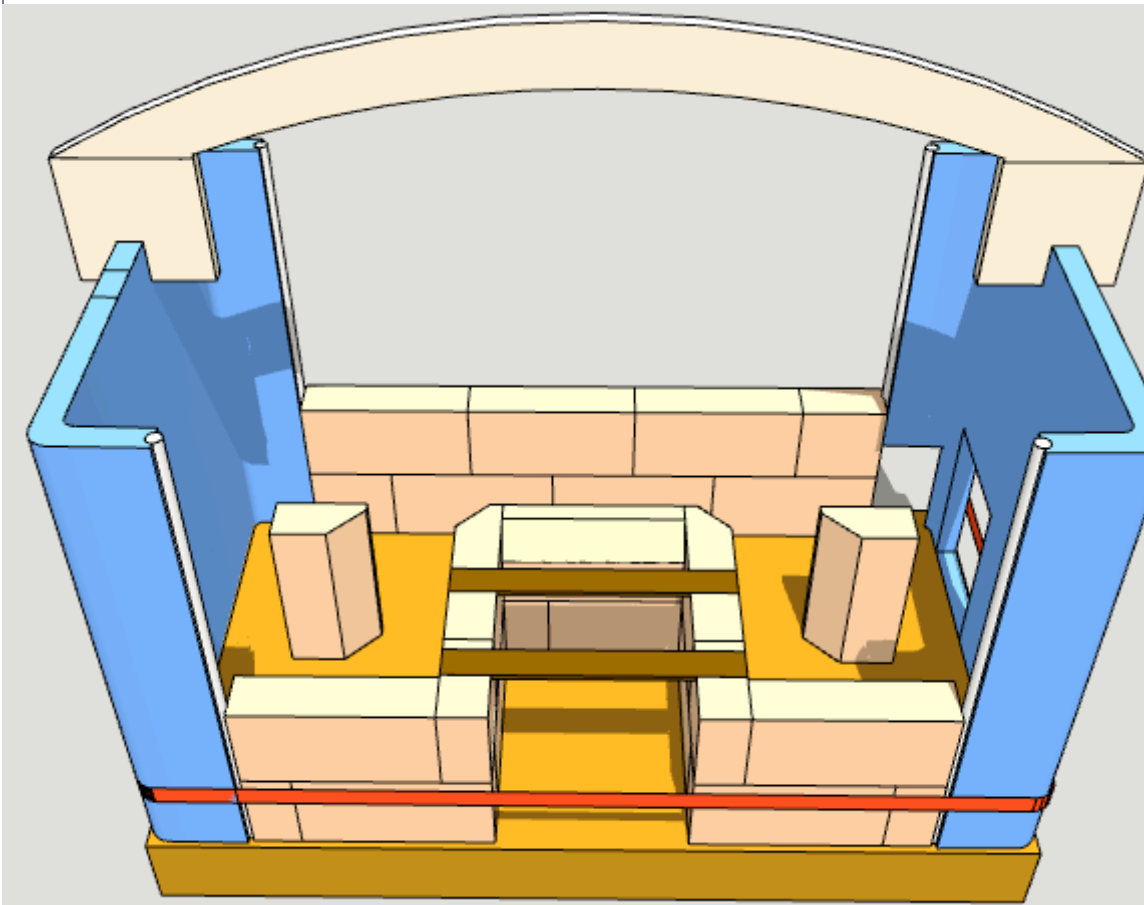
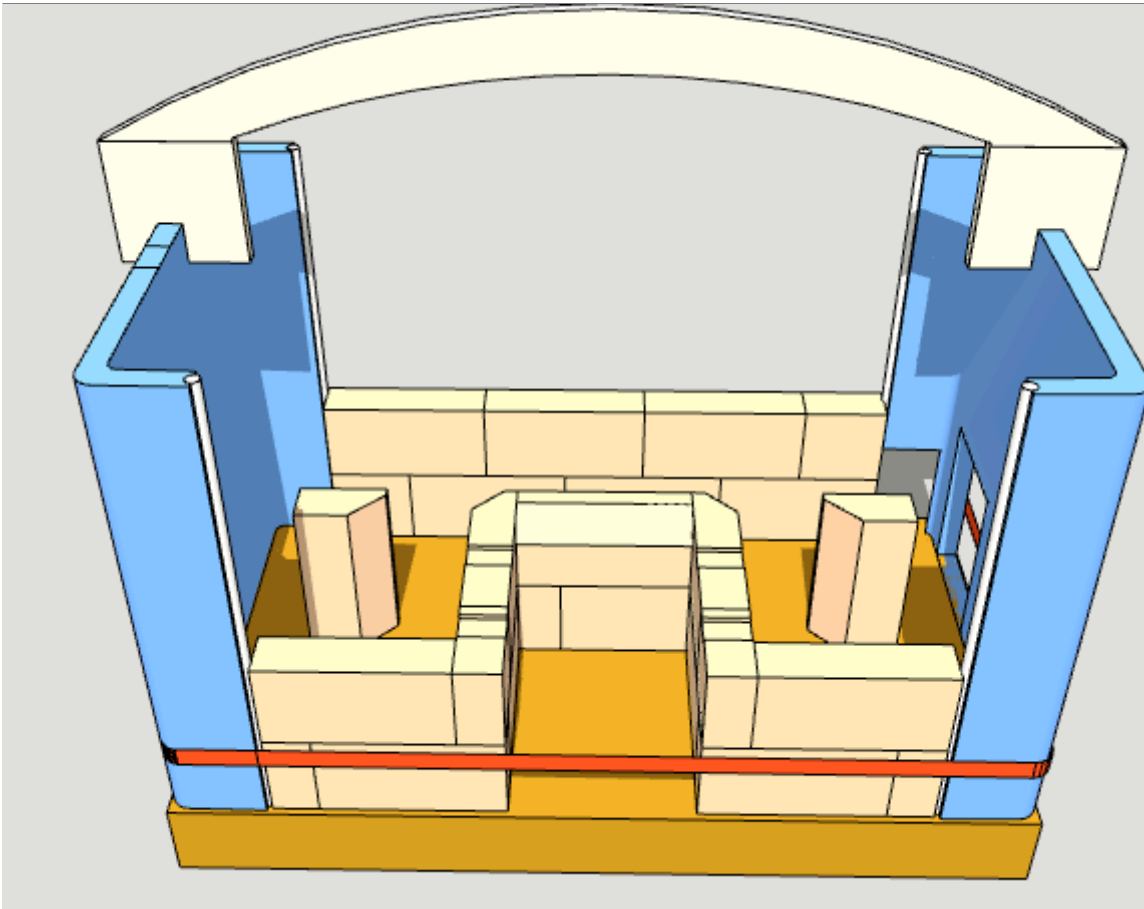

Set flat bars as shown. You can use a refractory mortar bed if they need levelling.

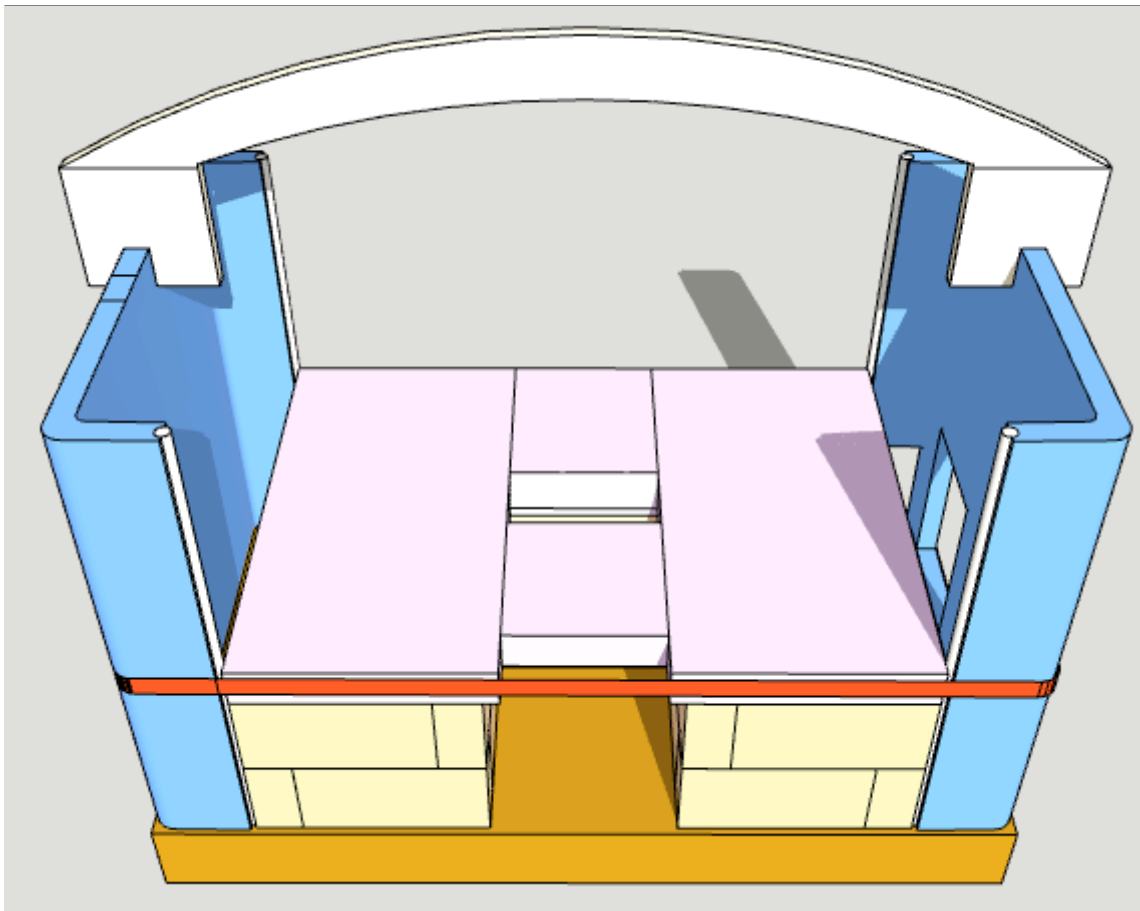

Set sub-floor slabs in refractory mortar. Use a thick bed to allow some room for levelling.

Refer to install video <https://vimeo.com/211742460> at 2:15.

Set the slabs flush with the front firebricks. Use the channel edges as a guide.

Note (below) that at the rear there will be a jump and the slabs are not flush with the firebricks below.

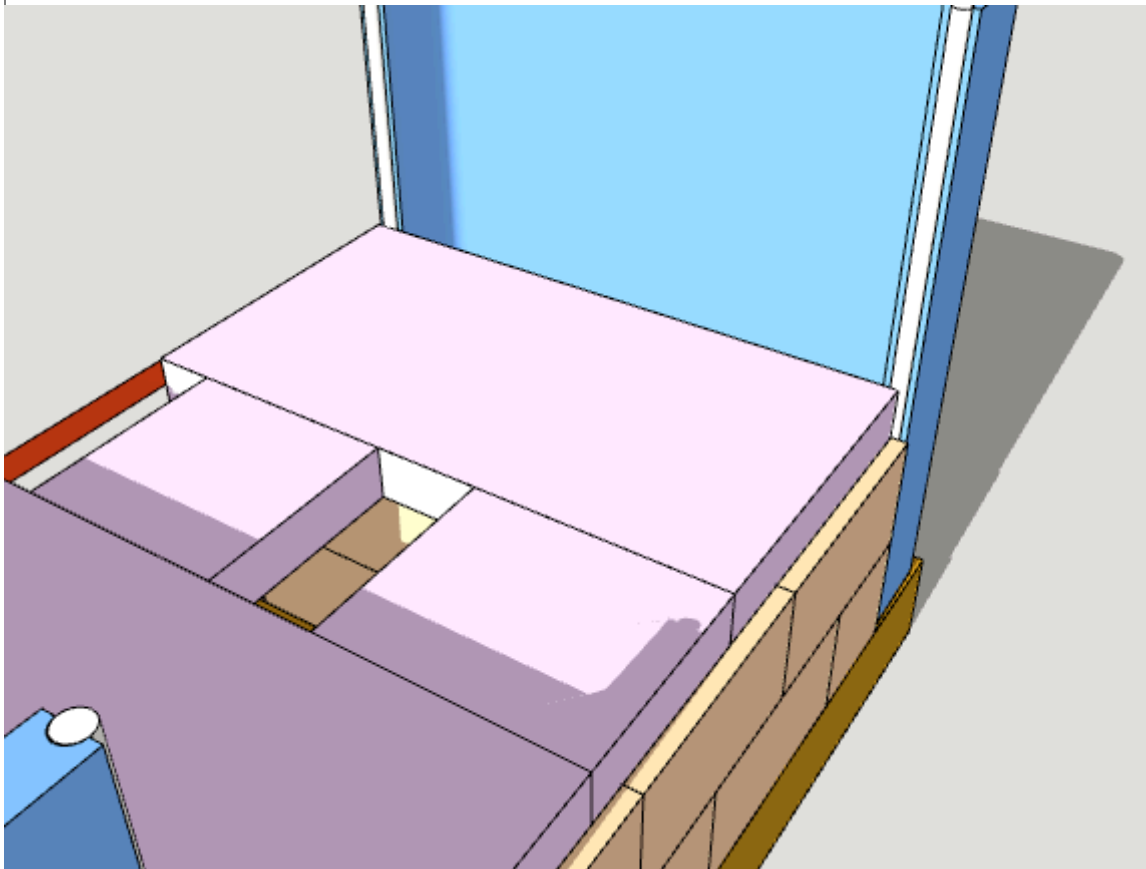

Raise the strap to the level shown above.

This will stabilize the channels enough that you can remove the plywood spacer.

This will give you better access for working

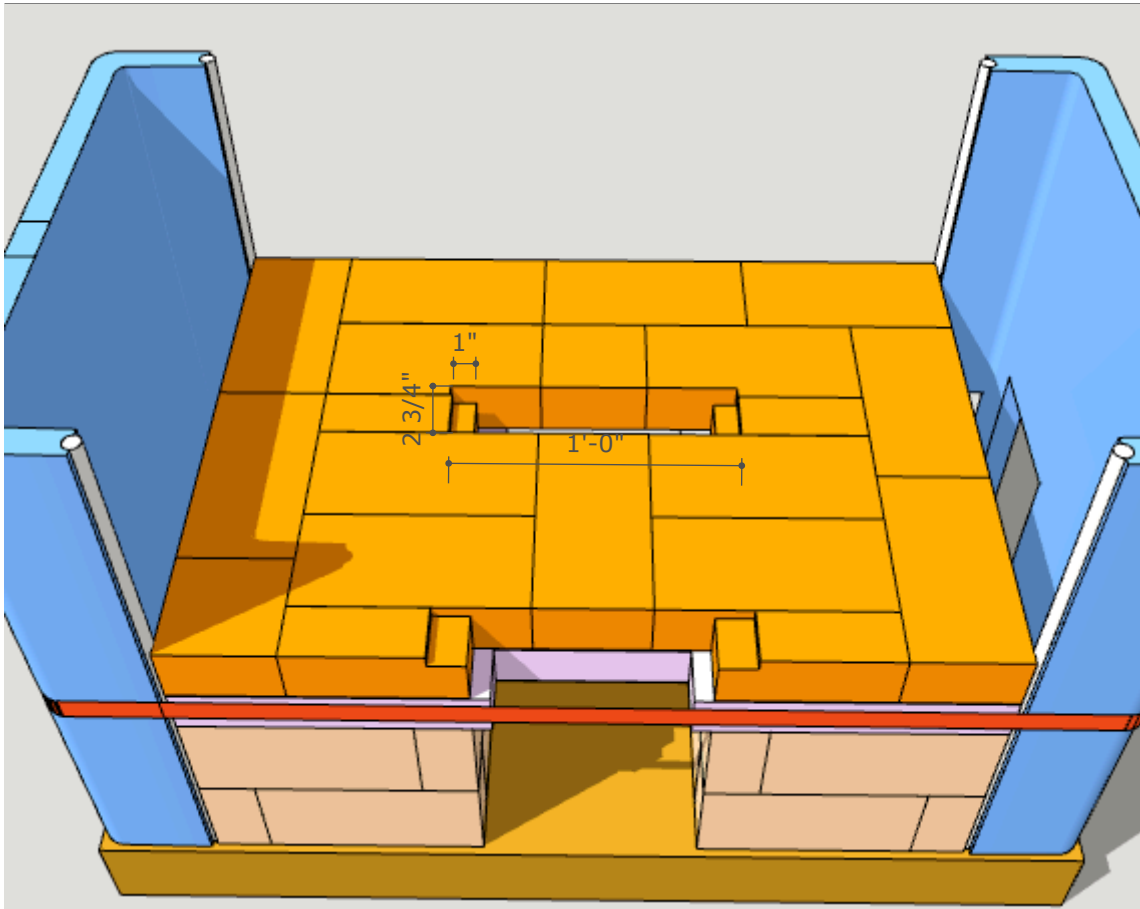

Do a dry layout of the firebricks for the firebox floor. You are using standard shapes - 1/2's and soaps. (Soap = firebrick ripped lengthways into two 9" x 2-1/4" pieces).

Cut the notches to fit the two grates.

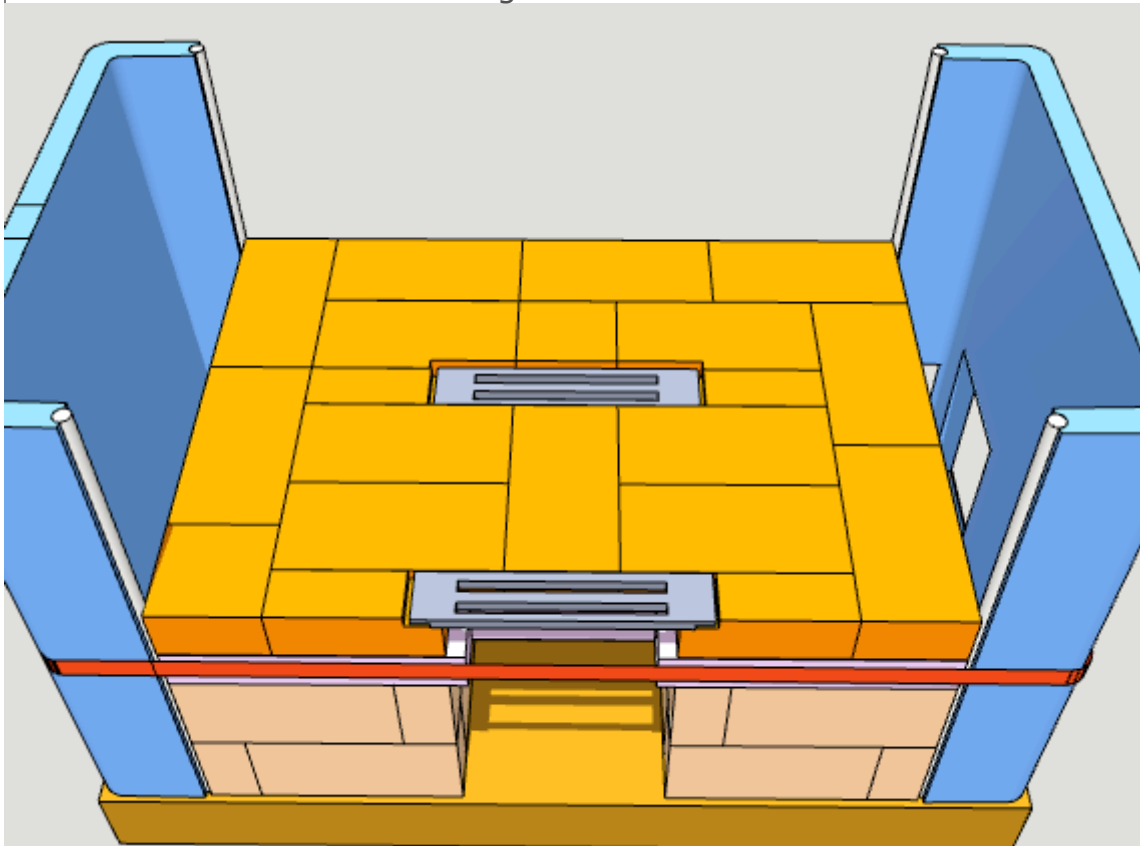

Set the floor bricks. Line up the rear corners with the slabs below, using the channels as a corner guide for the rear corners.

See next page for notes on setting firebricks with refractory mortar.

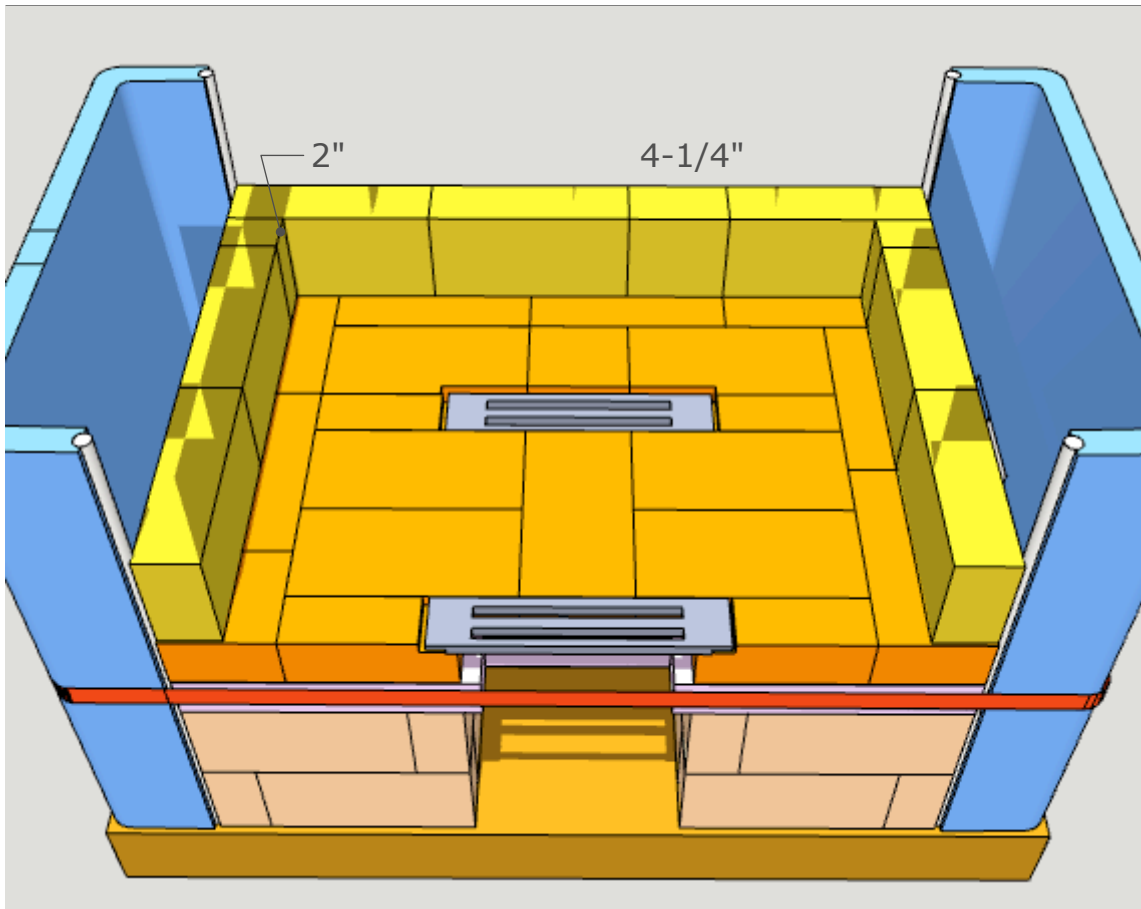

Lay out the firebox as indicated, using air setting refractory mortar.

Non-standard cuts are indicated by dimensions (2" and 4-1/4" here) instead of the standard firebrick shapes i.e., 1/4, 1/2, 3/4, full

Firebrick corners sit dry against the fiberglass rope gaskets.

Channel edges act as corner guides.

Outer width of firebox is 31 1/2".

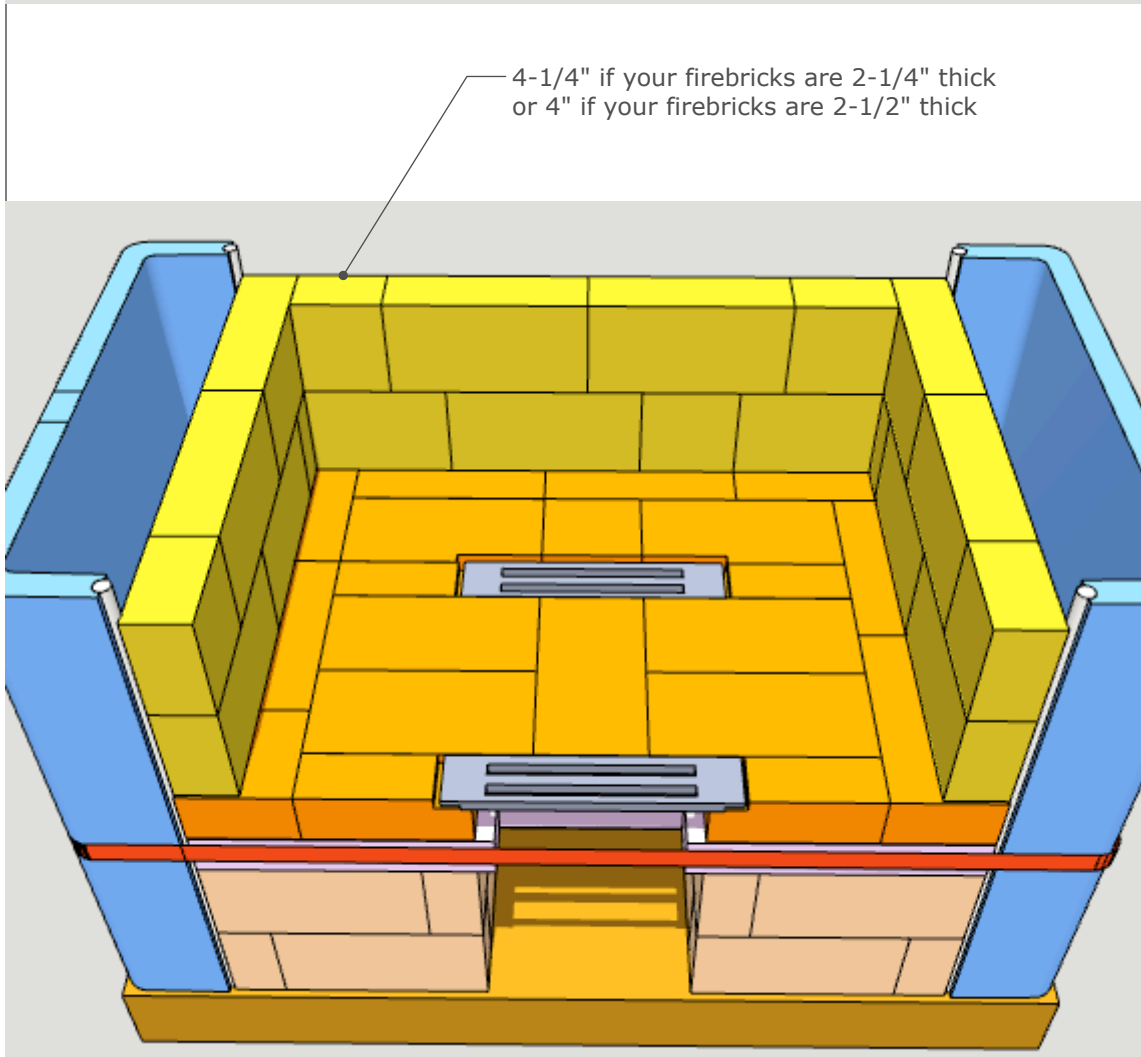

Exact bond is dependent on firebrick thickness, generally between 2-1/4" and 2-1/2".

Front bricks on the second course are halves. Put the cut side out (towards the front).

The grates are shown for reference only. Better to install them at the end.

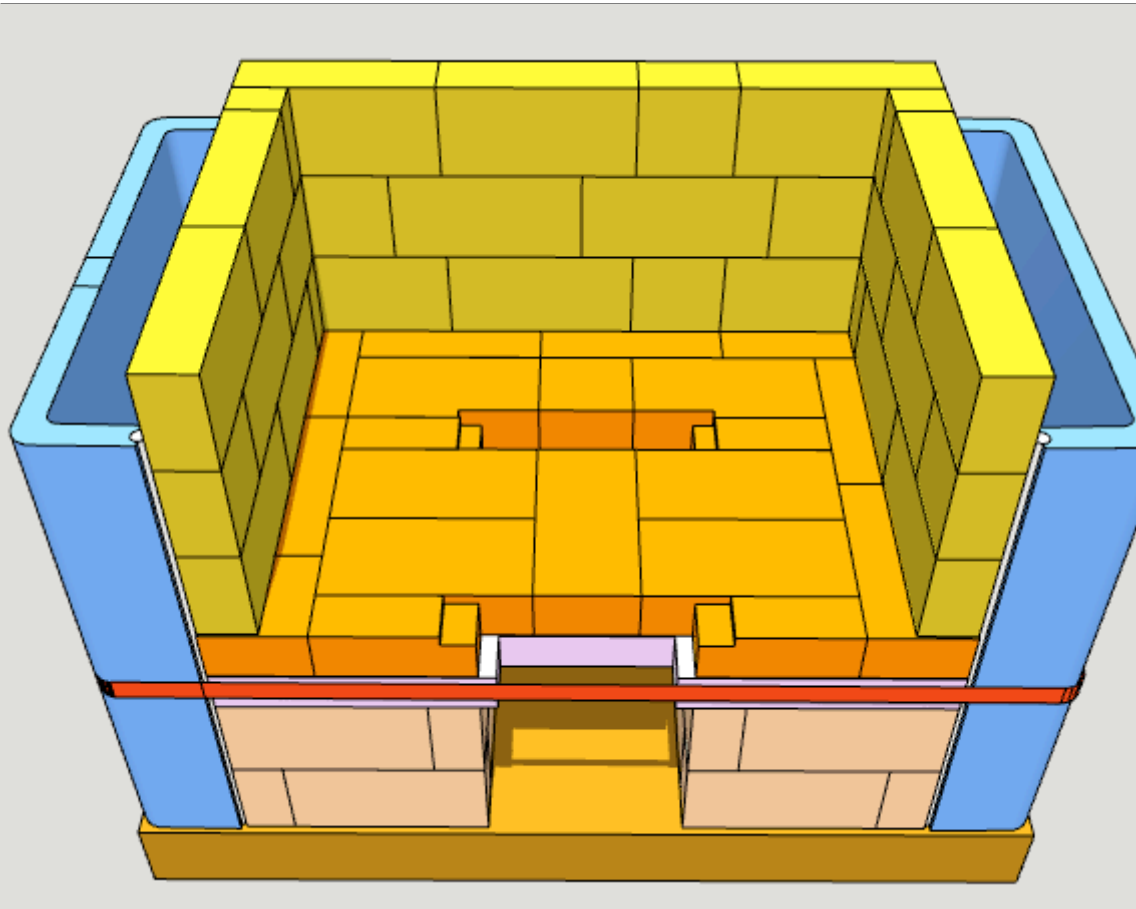

(Below):
Completed outer shell
of firebox.

Top front firebricks are
notched 1/4" x 4" for
firebox lintel.

Install next set of side
channels onto a
refractory mortar bed.
(see next page showing
plywood spacer).

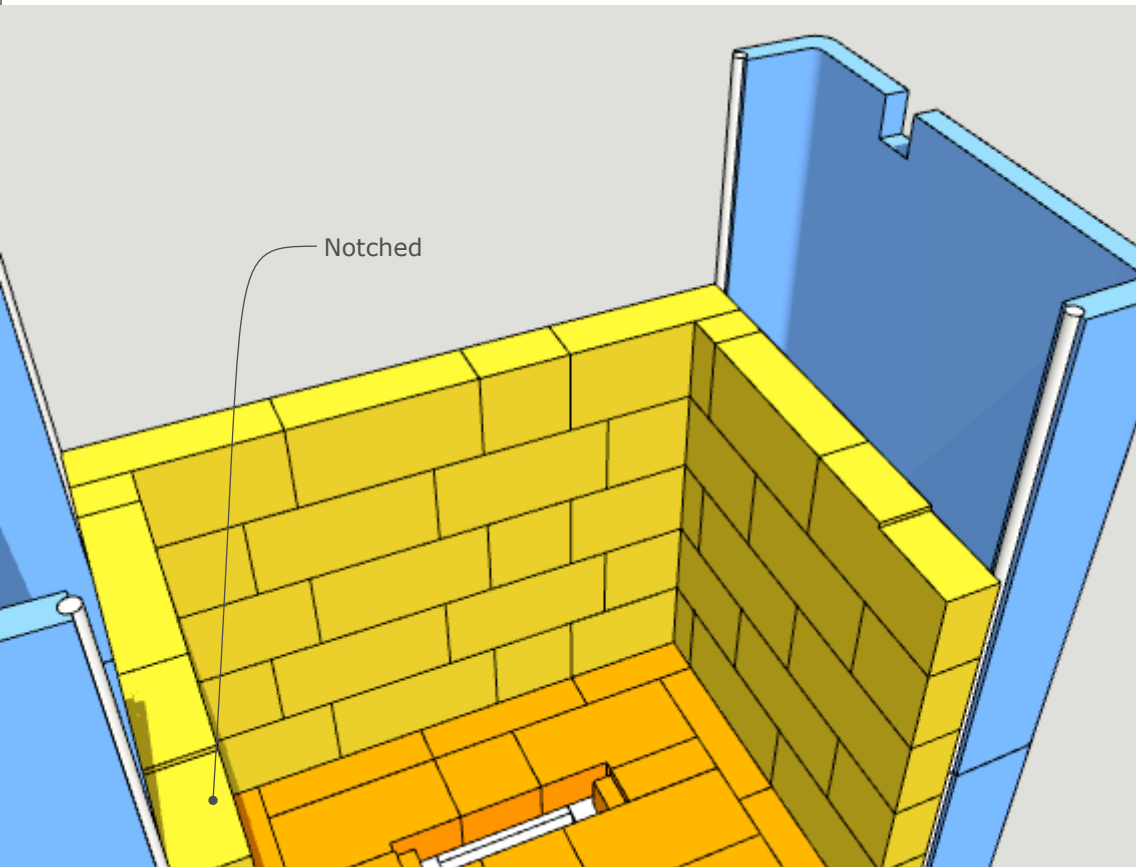

Clean up any mortar
squeeze out inside the
channels.

Note the 2" x 2" notch.
This is a permanent
bypass, to help warm
up the chimney when
the heater is started
cold. It is located
wherever your chimney
is (right side towards
the rear in this
example).
Cut the notch before
installing the channel.
Just cut two vertical
kerfs, and you can pop
the piece out with your
brick hammer.



Gas slot details:

For easier heater startup during difficult conditions (cold heater, warm outside temperatures) we highly recommend installing a gas slot. This consists of a 2" X 2" direct connect.

Cut a notch in the channel at the appropriate location to line up with the flue liner where the chimney will be.

Later, when facing the heater, create the direct connect to the flue liner by using firebricks or firebrick splits

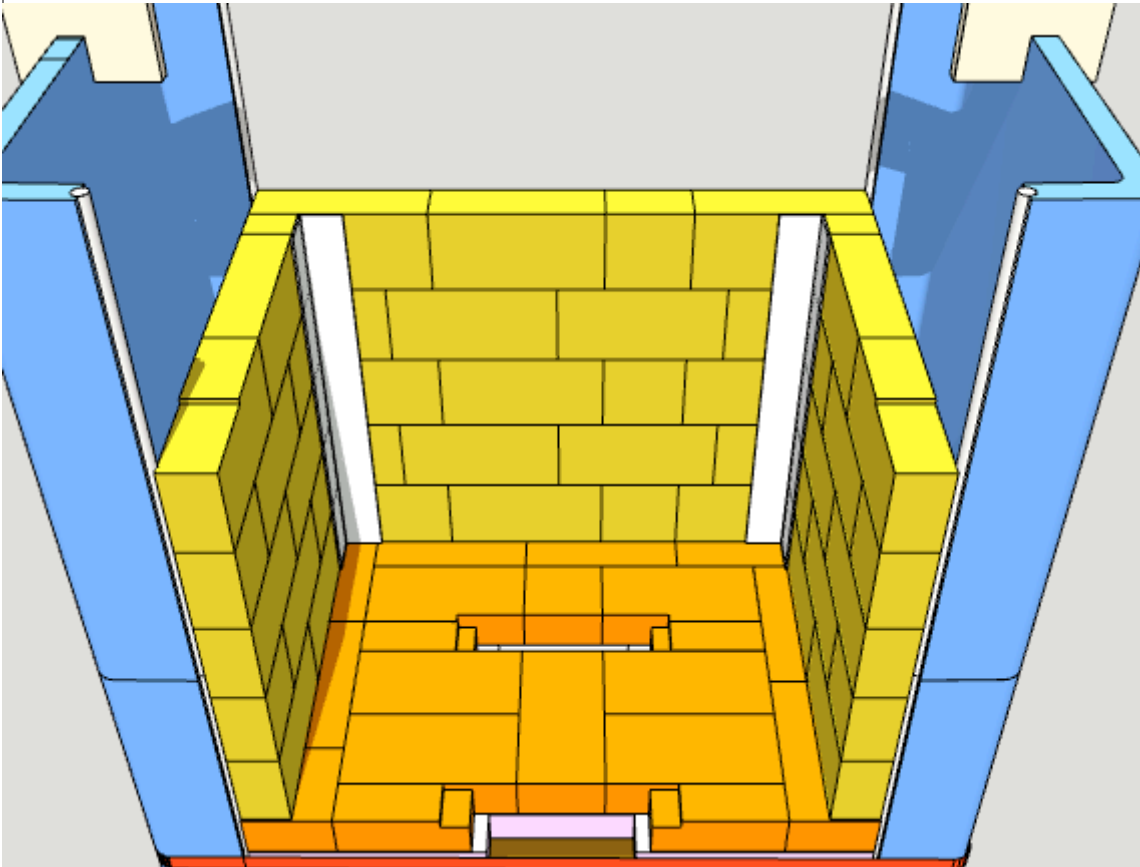
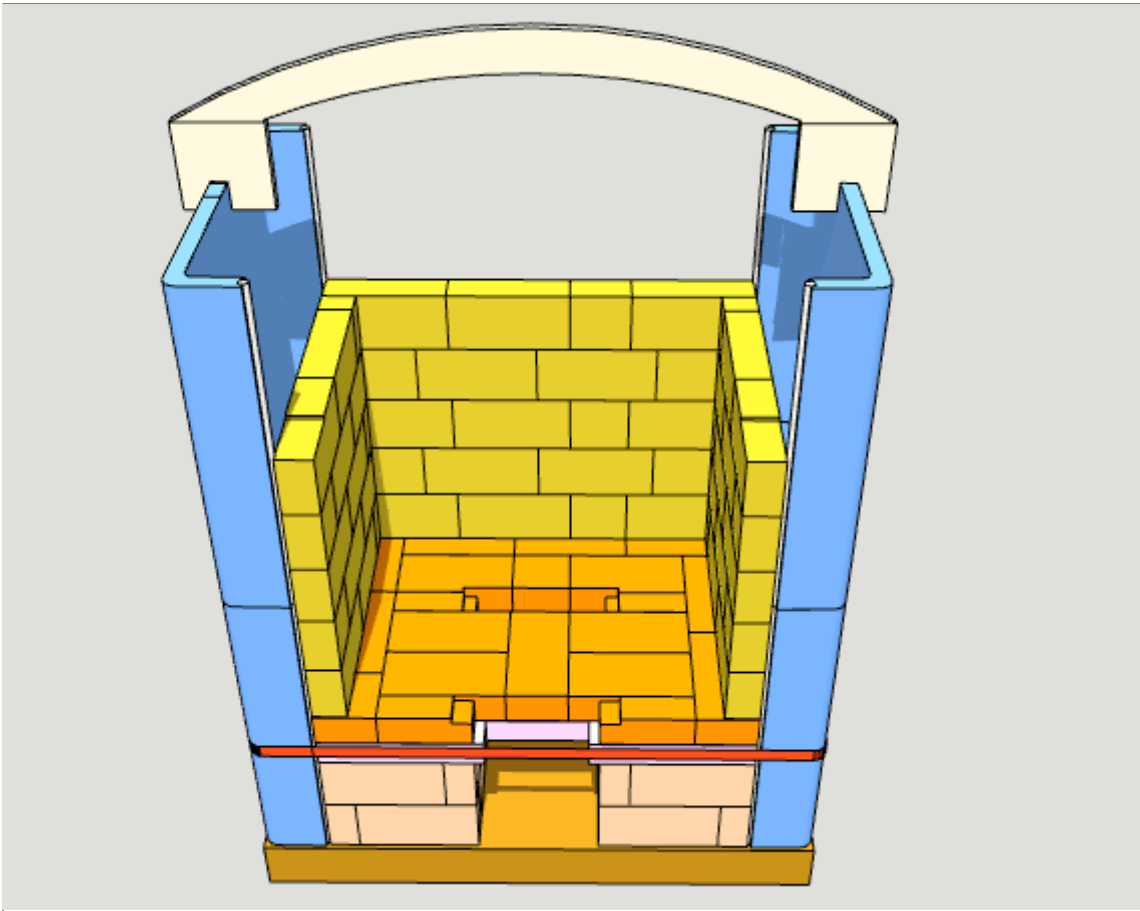

Install two 2-1/4" strips of ceramic paper (supplied) at the rear corners. A few light dabs of refractory mortar will hold them in place.

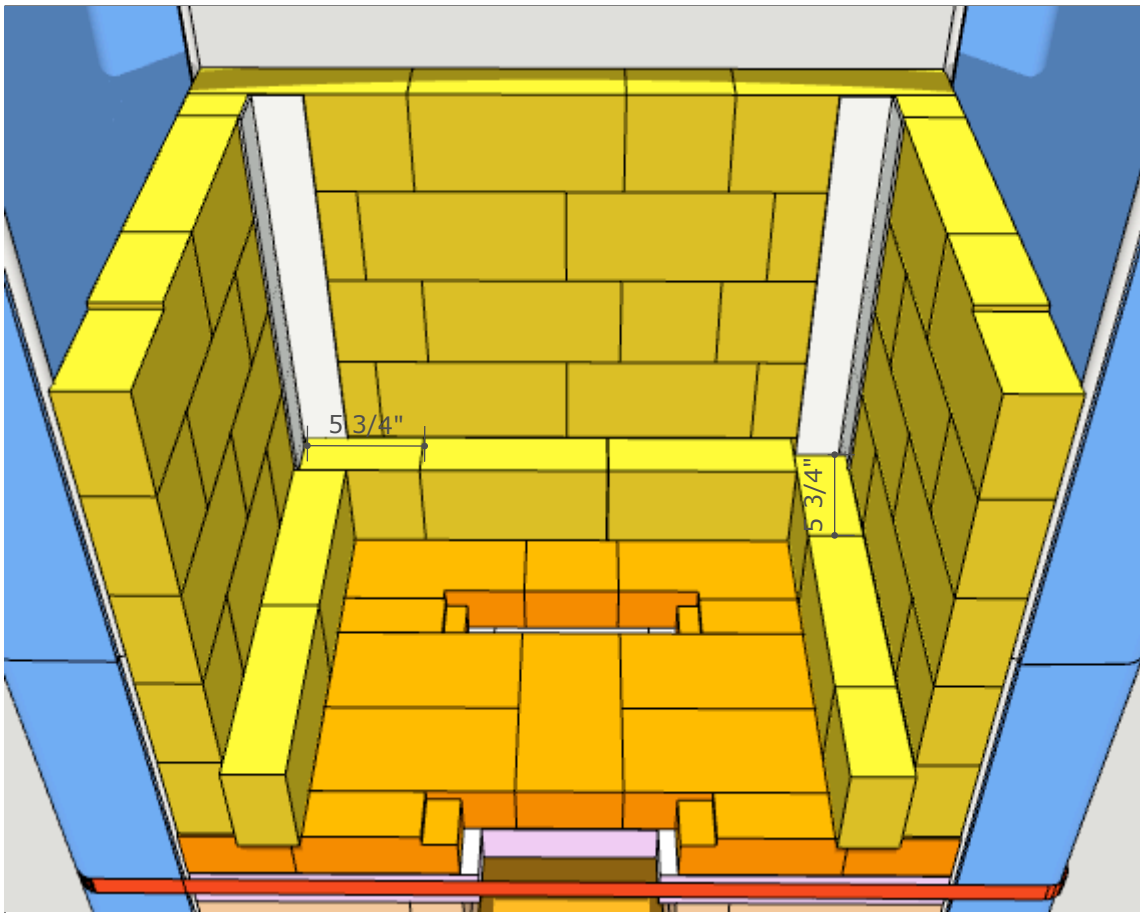

Begin inner firebox. Note that the bricks are left about 1/4" - 1" short at the blind inside corners. The cut edges on these bricks are hidden.

On each course, you begin with the half brick at the front. Depending on the thickness of your firebrick, it will project past the outer firebox. This is OK.

However, for your first brick you do not know yet what this projection will be.

Do a dry layout of the first course to determine the projection, usually around 1/2".

The inner firebox is set dry against the outer firebox. There is no mortar joint between the two fireboxes.

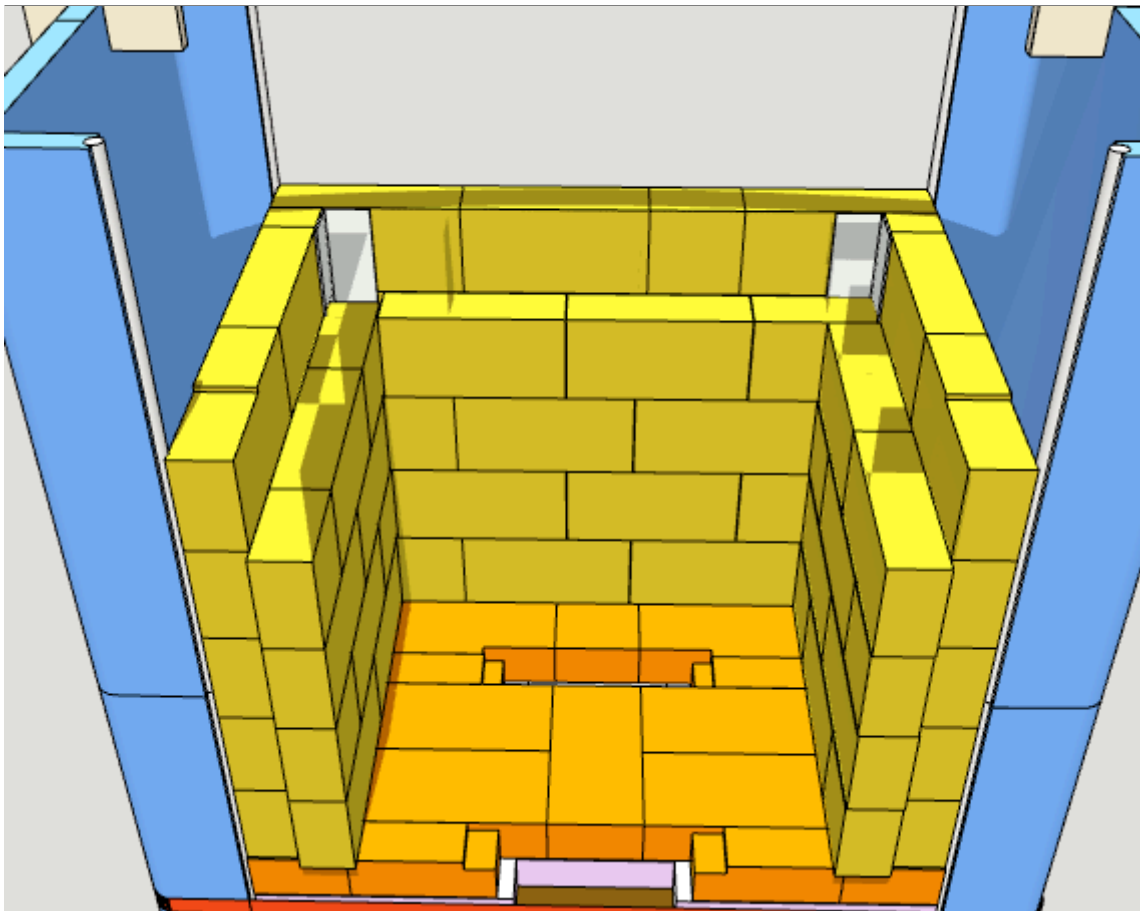

Your second course will be same as the fourth course, which is shown here.

It is the same as the first course, except the half brick starts on the left.

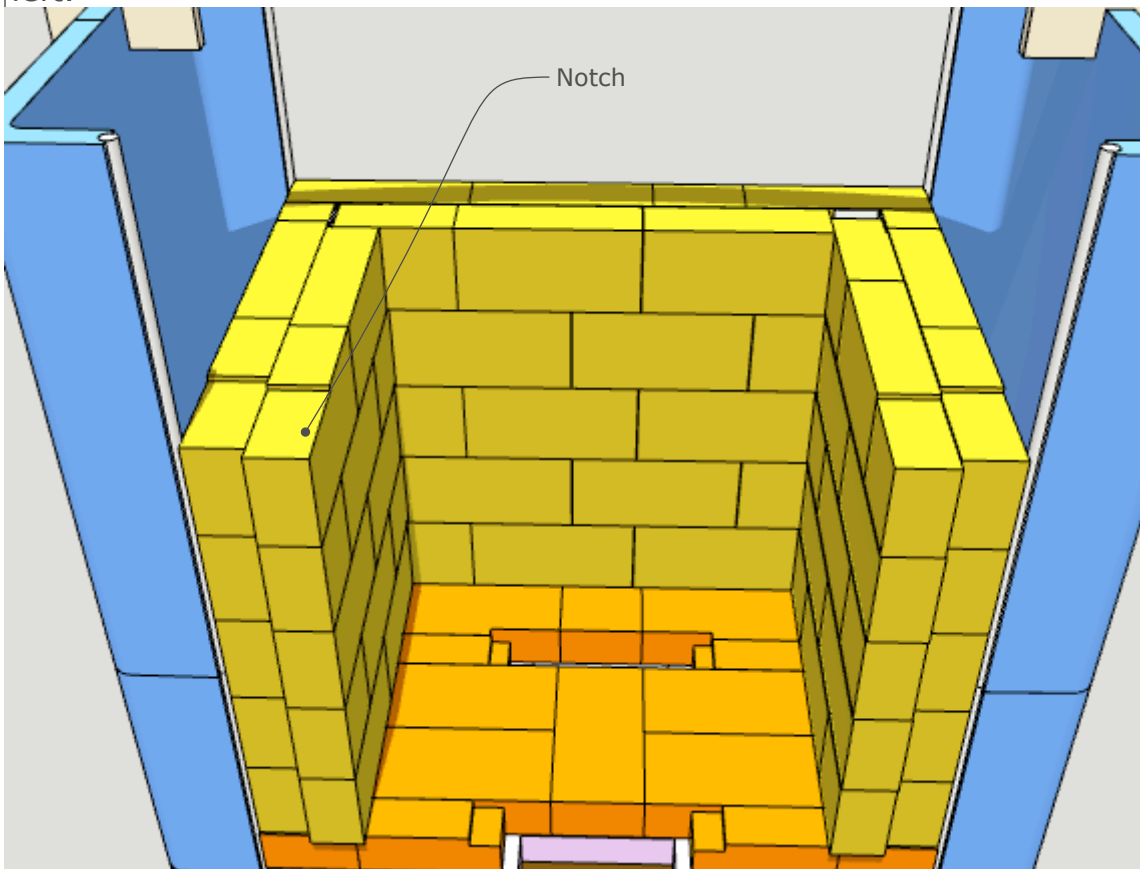

Notch top course of firebox liner as shown.

Notches are
1/4" x 4-1/4"

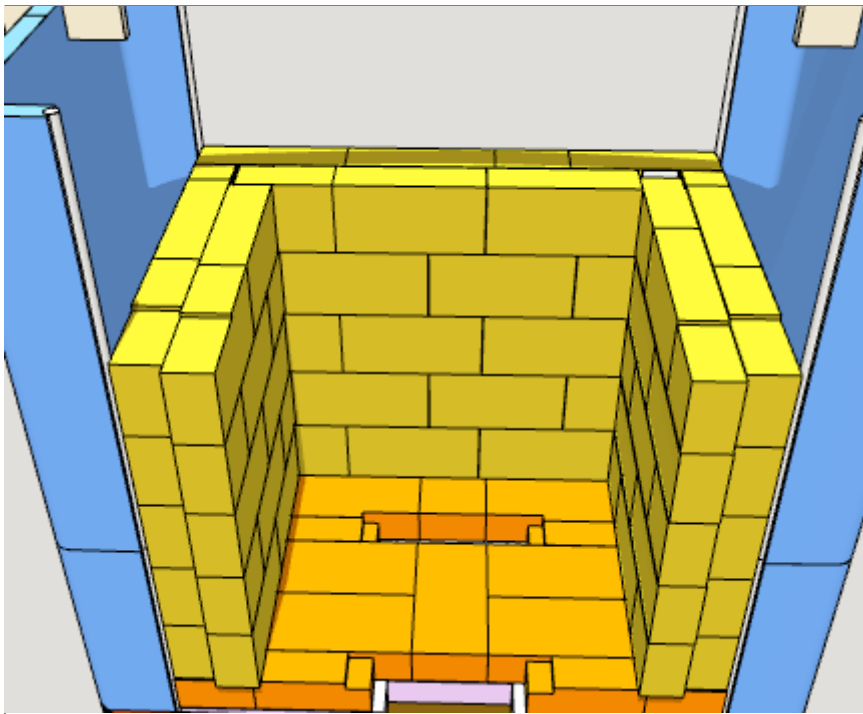

Immediately wash down the firebox with a sponge and a liberal amount of water. Rinse with clean water.

If this is done right away, it is easy to get a clean looking firebox.



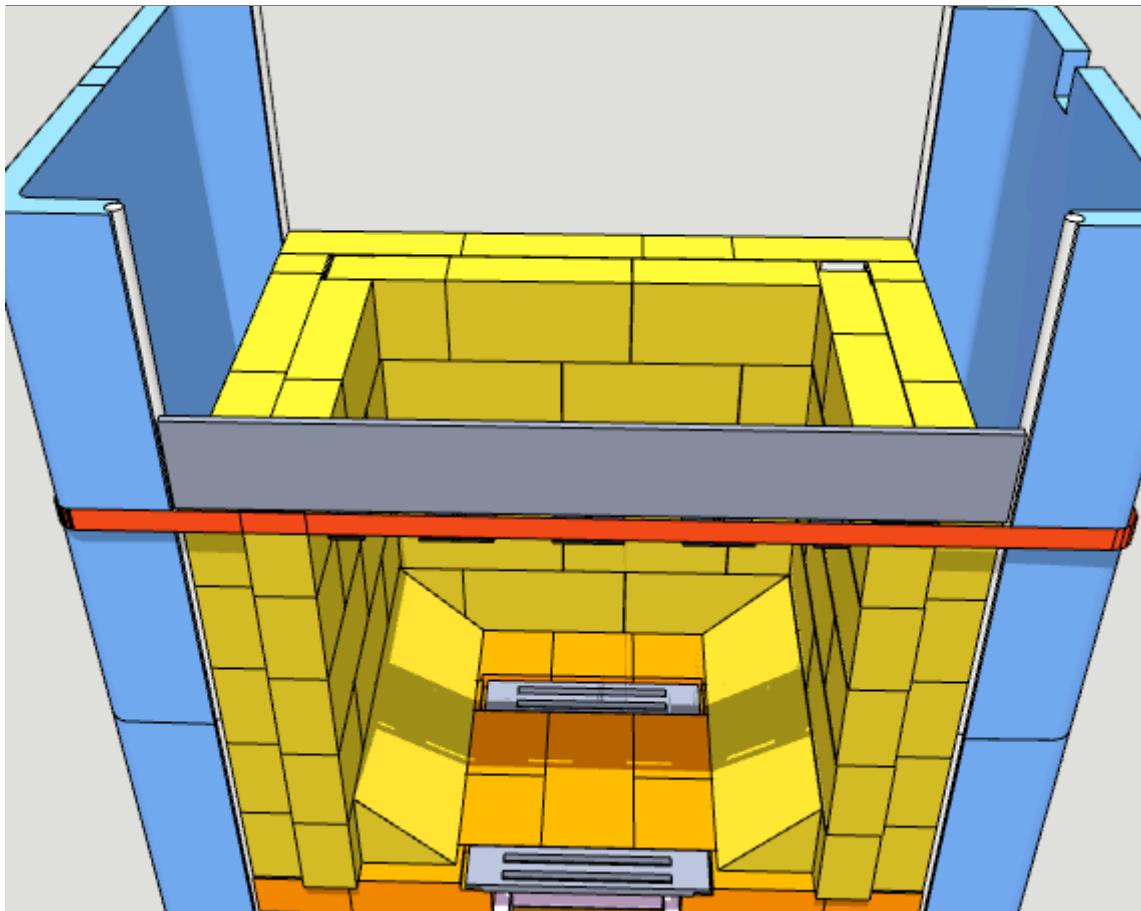

Install firebox lintel.
Use a refractory bed
under the ends if they
need levelling.

Vertical face is slightly
proud of channels, see
bottom illustration.

Raise strap as shown,
so that you can remove
the plywood spacer for
easier access.

The precast firebox
floor slopes are shown
for completeness.
However, it is better to
install them at the end.

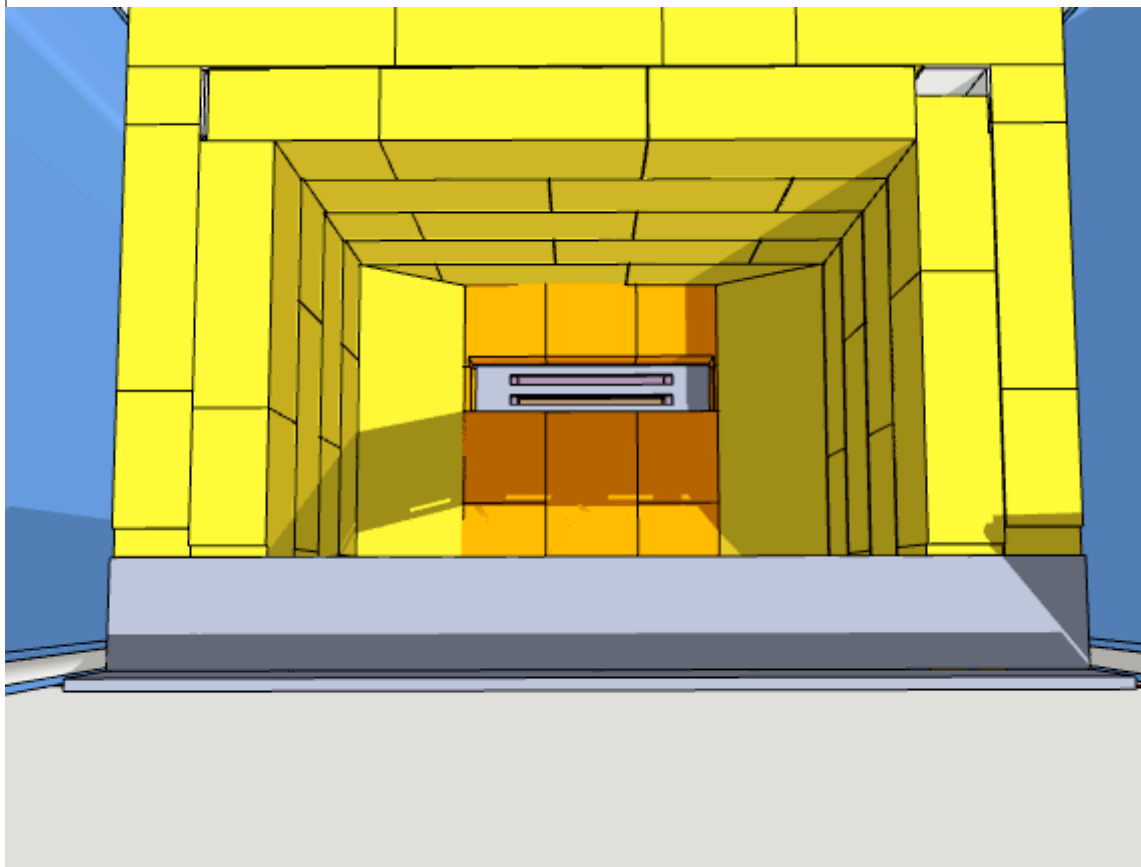

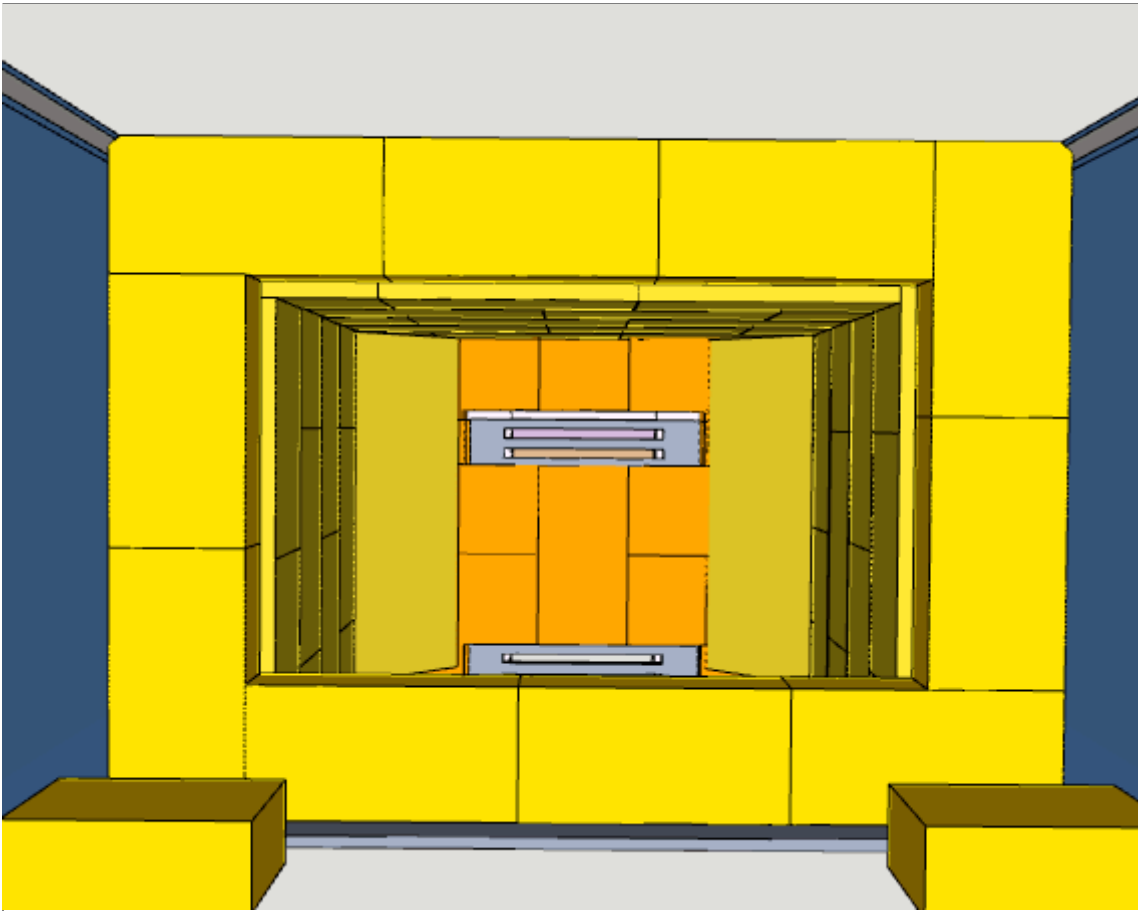

Building the Upper Firebox:

Rear Bake Oven:
The drawings show a front bake oven. For a rear oven, reverse the plan at this point. In other words, flip the remaining layout by 180 degrees.

If you have access to strapping tools, this course can be strapped as shown on the next page. This is optional. If a strap is used, then round outside corners of bricks slightly.

The purpose of the strap is to transfer weight onto the outer firebox. This allows the complete inner firebox to be removed, if necessary, rather than in sections.

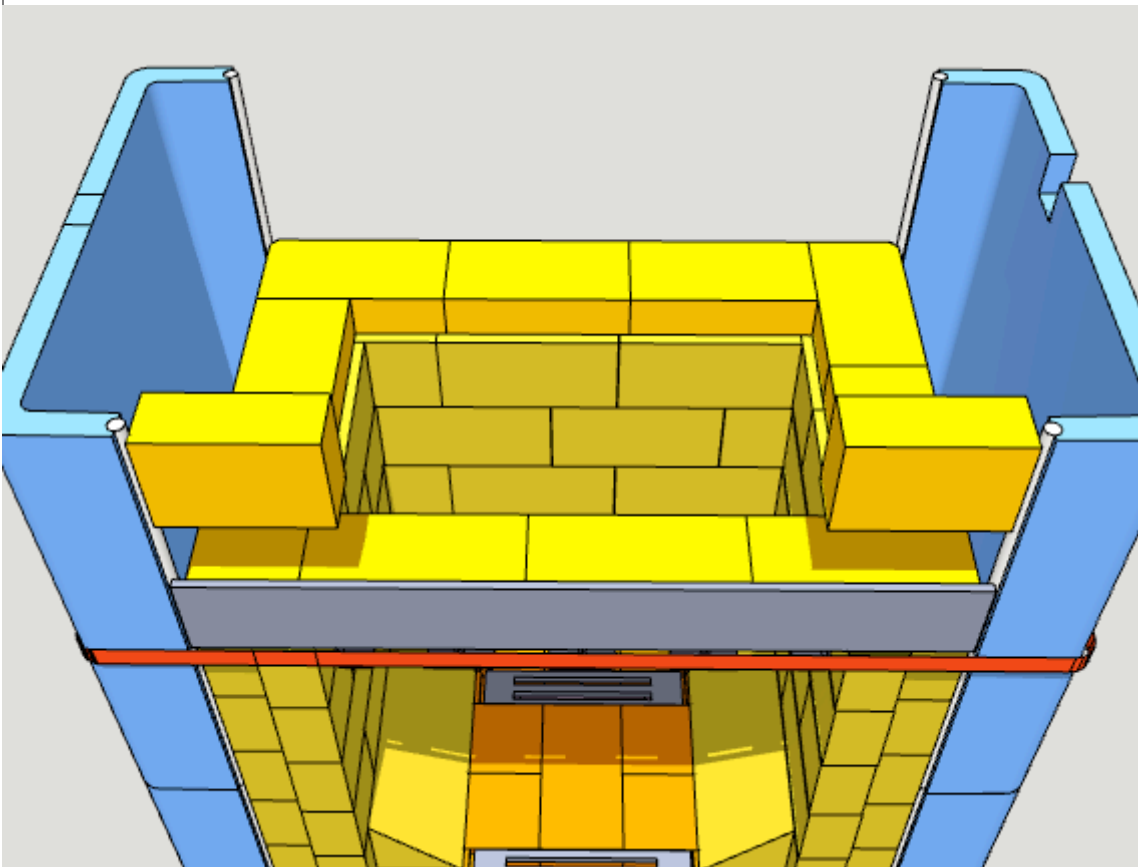

For the bricks that sit on the angle iron, round their bottom front edges slightly, to allow a tighter fit against the angle iron. Leave about 1/16" gap if you will be strapping this course.

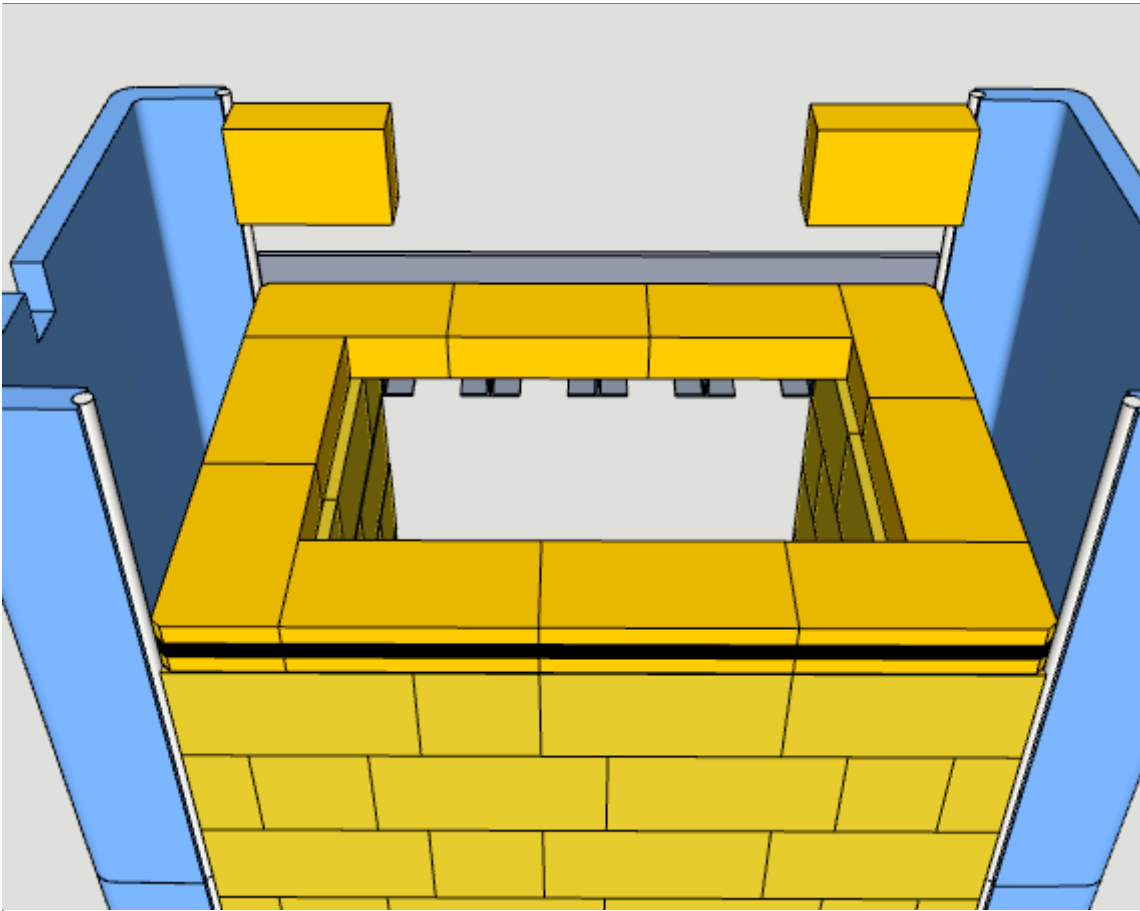

Course strapped with 5/8" steel strapping (optional).

Strapping runs inside the lintel, next to the brick.

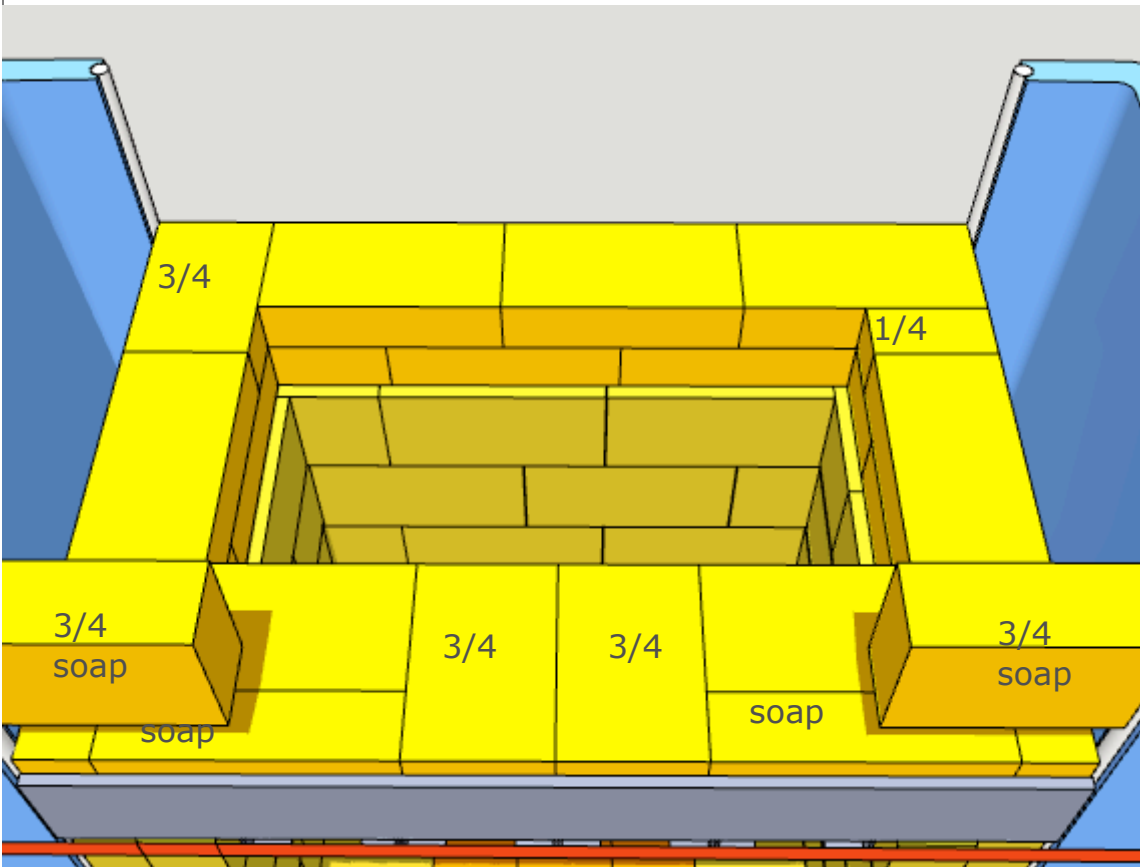

Next course layout.

Three 3/4 bricks
(6-3/4")
One 1/4 brick (2-1/4")

2 soaps (bricks ripped lengthwise)

2 three-quarter soaps
(6-3/4" long)

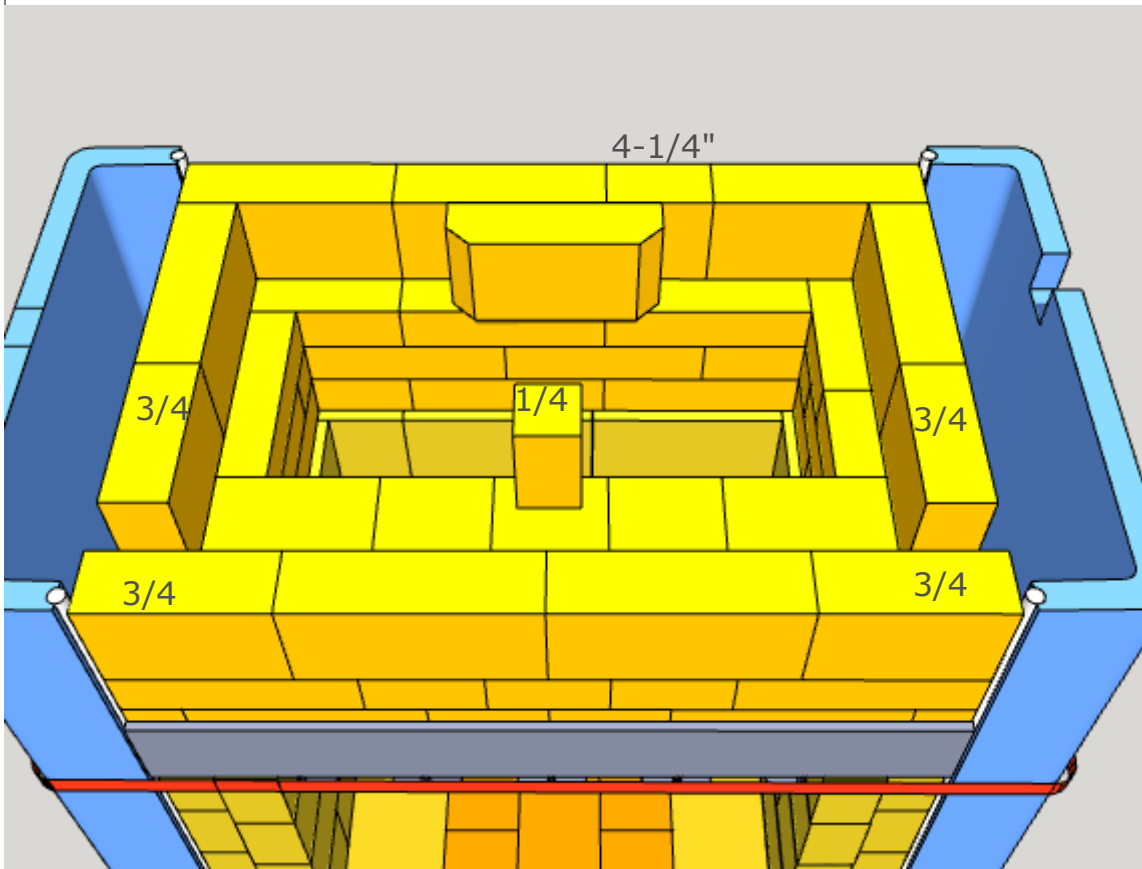
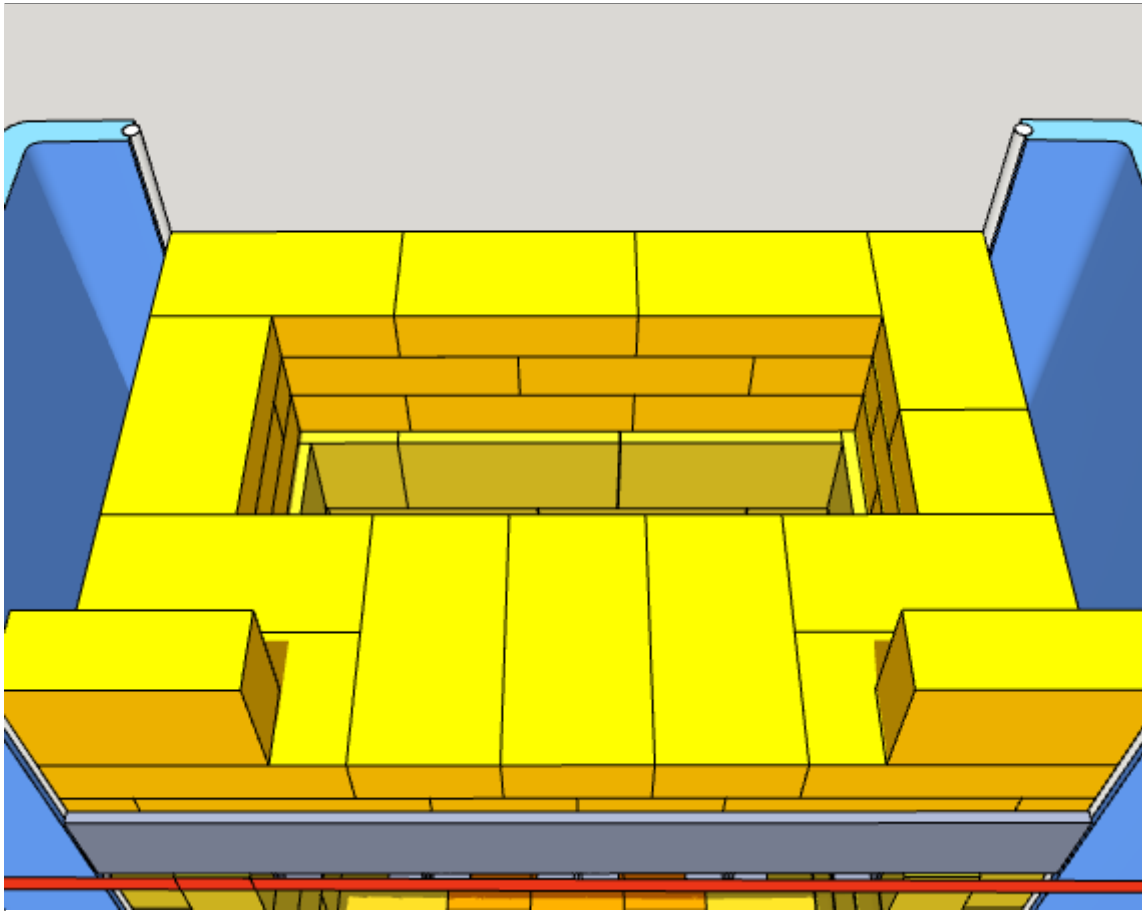

This is the course that the oven floor will sit on (see next illustration).

For the portion that will support the floor, take extra care to level the bricks. This will make it easier to level the floor.

Determine your high spot, and work from there. Use fat joints under the lowest spot if needed.

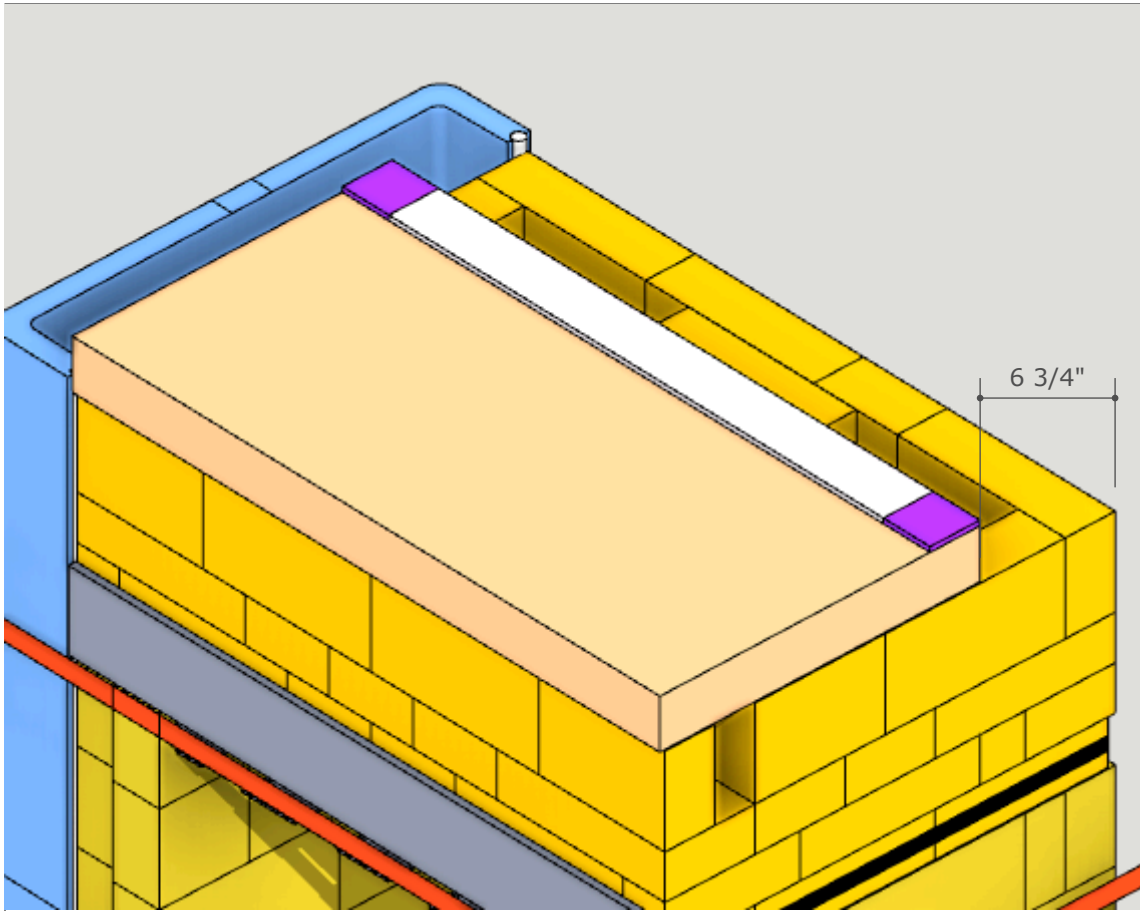

(Side channel not shown)

Set oven floor onto a generous mortar bed. Note that it will overhang in the front about 1/4"

Set it down carefully to avoid mortar squeeze out, to allow you some room for levelling by tapping down the high spots.

Set the two metal corner shims with the location pins into the predrilled holes.

Cut and set a strip of 2" wide ceramic paper gasket where shown.

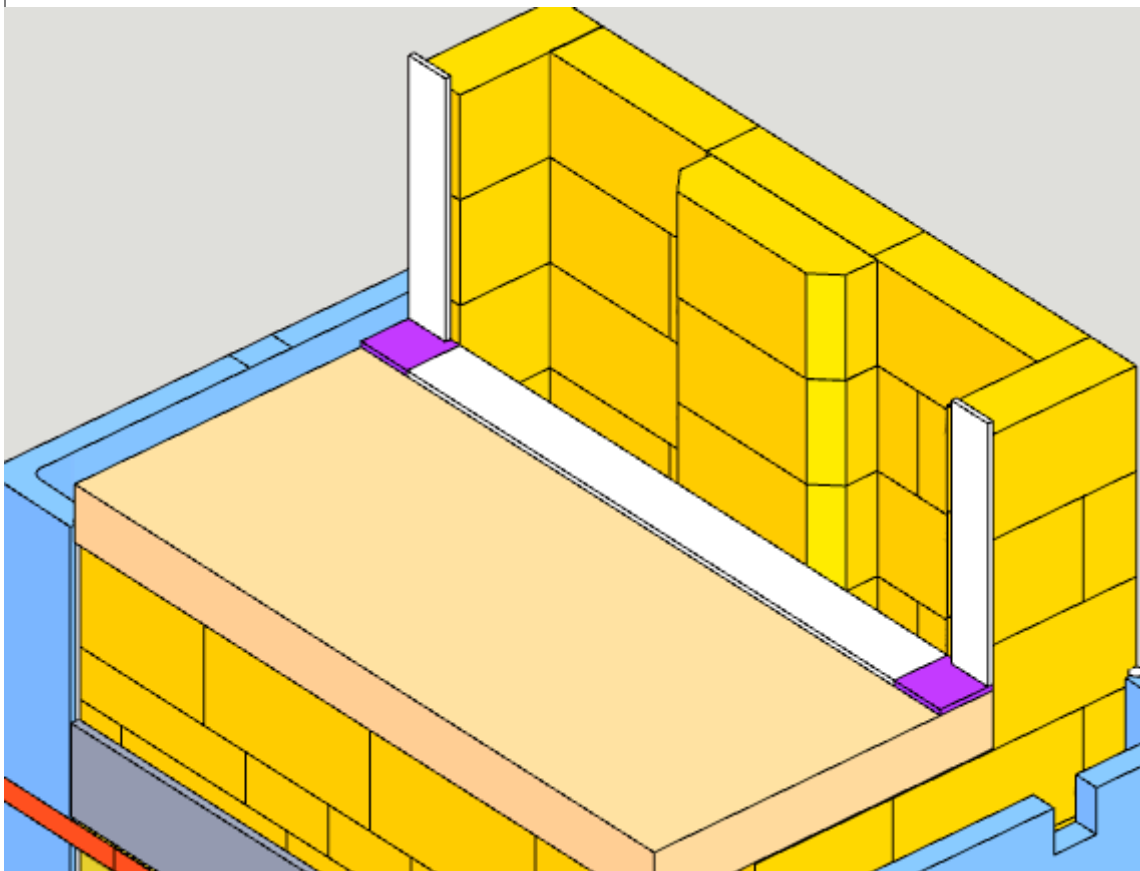

Build up the rear wall as shown. The brick bond shown works for 2-1/4" thick firebricks. If your bricks are 2-1/2" thick, trim one of the full sized bricks by 1/2".

For the stacked bricks in the thickened center, ensure full mortar joints, especially with the rear wall. Rub the bricks into the rear wall.

Add the two gasket strips shown.

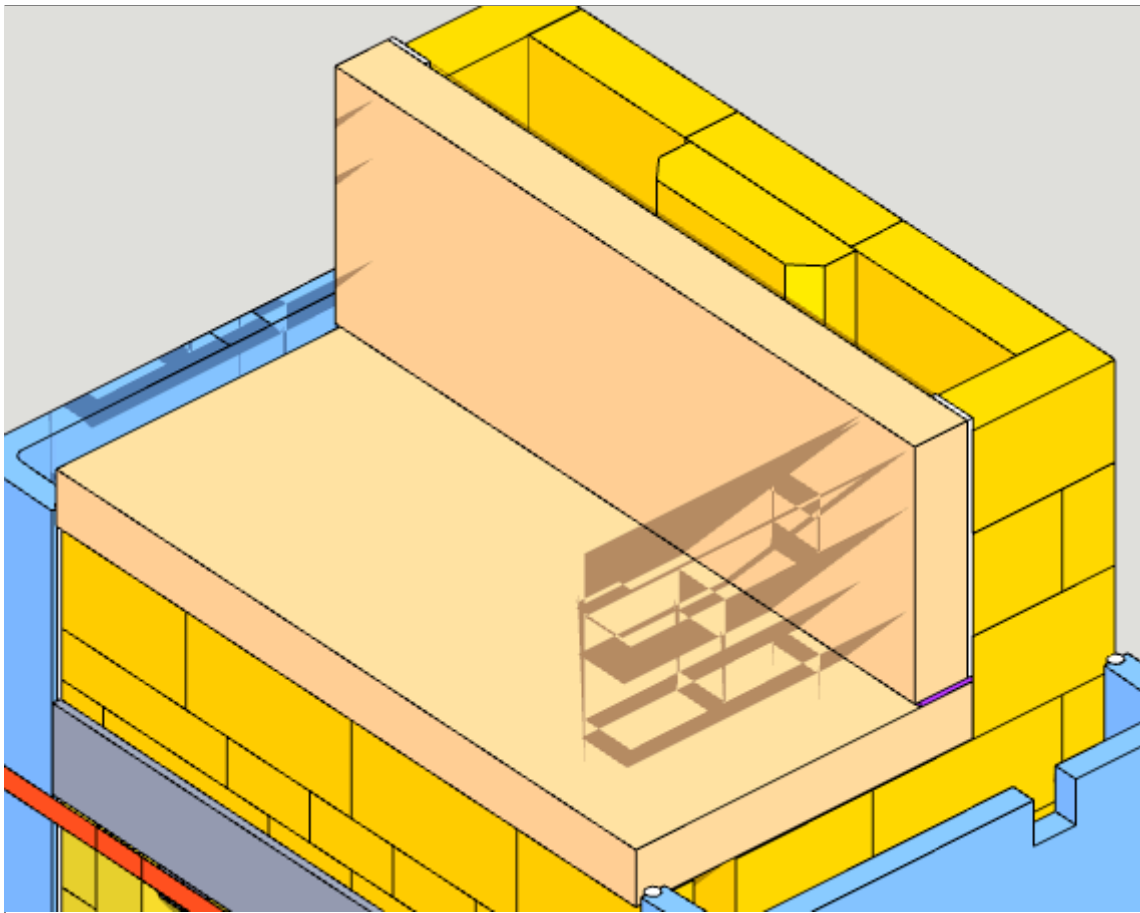

Set the rear wall dry.

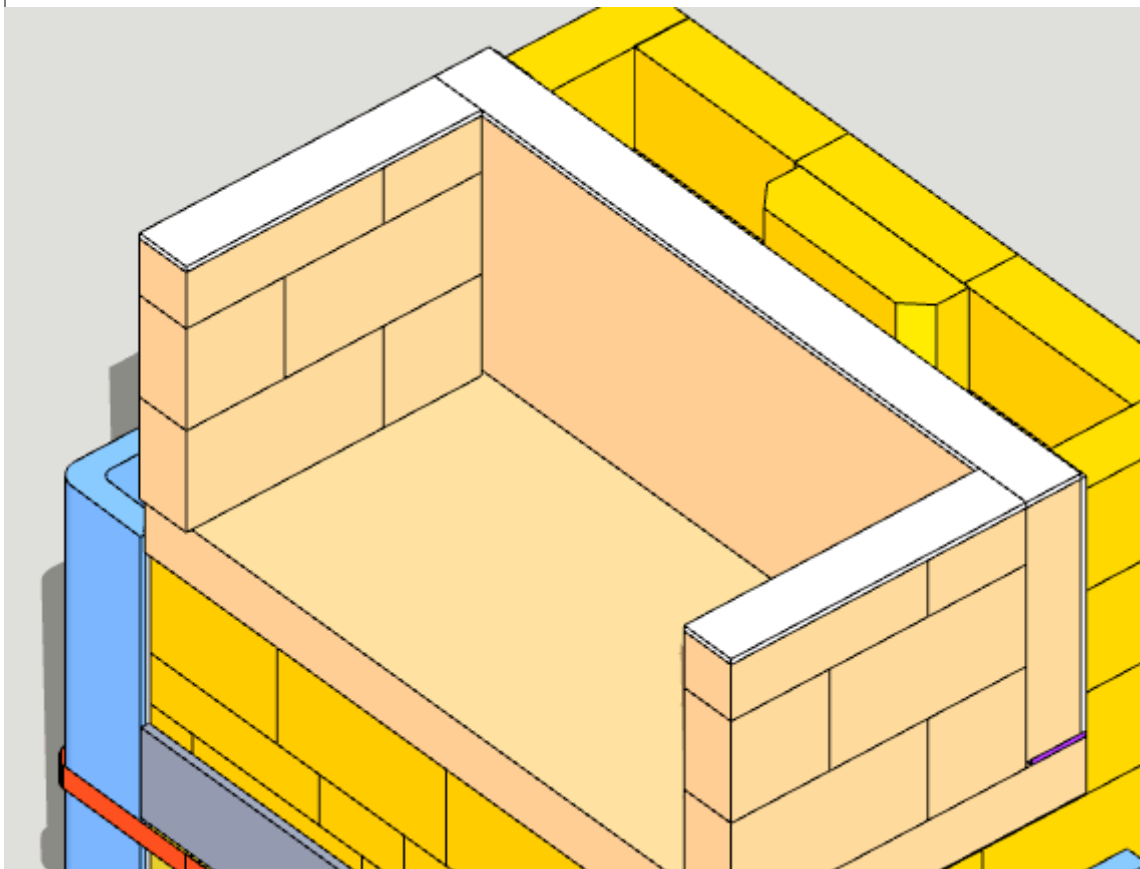

Build up the sidewalls from firebrick shiners.

Use a mortar joint against the rear wall.

Install gasket as shown. Use a thin coat of refractory mortar to glue the gasket, to avoid movement when you install the ceiling slab.

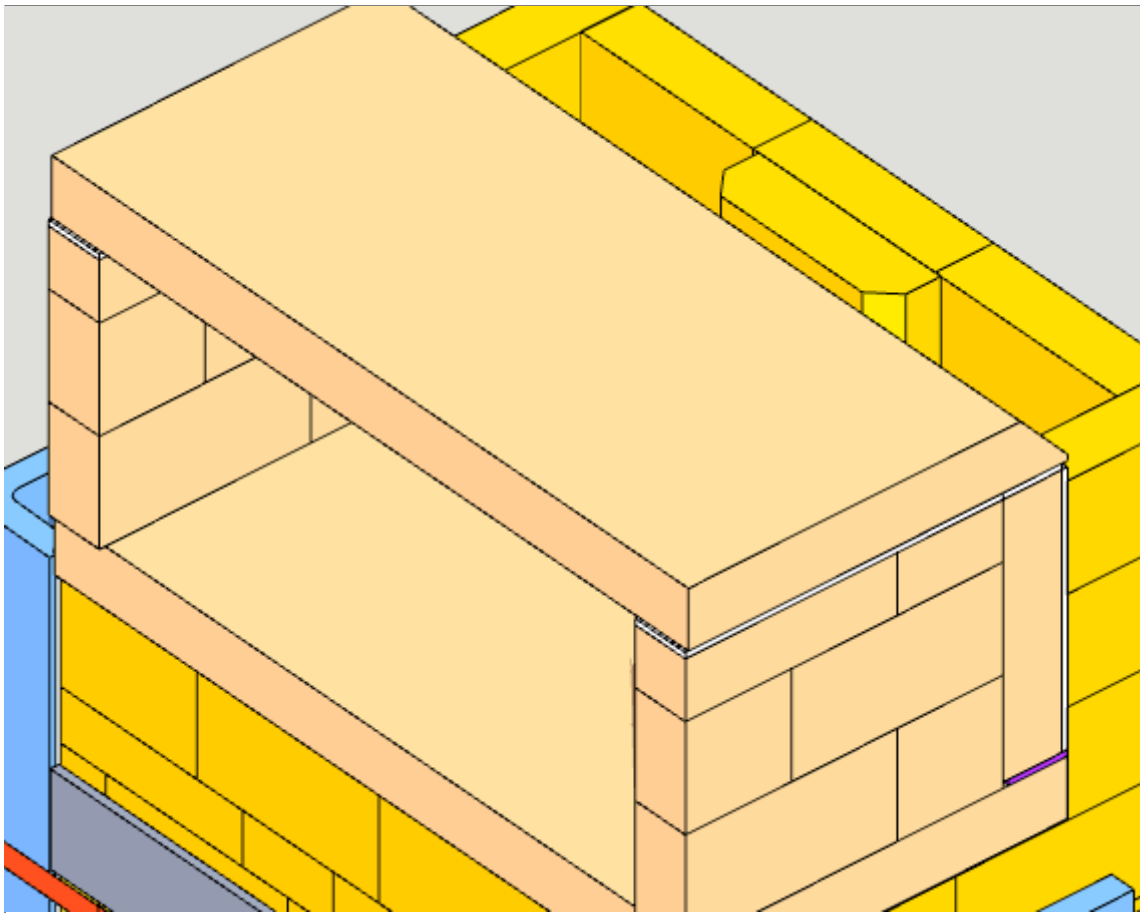

Install oven ceiling dry onto ceramic paper gaskets.

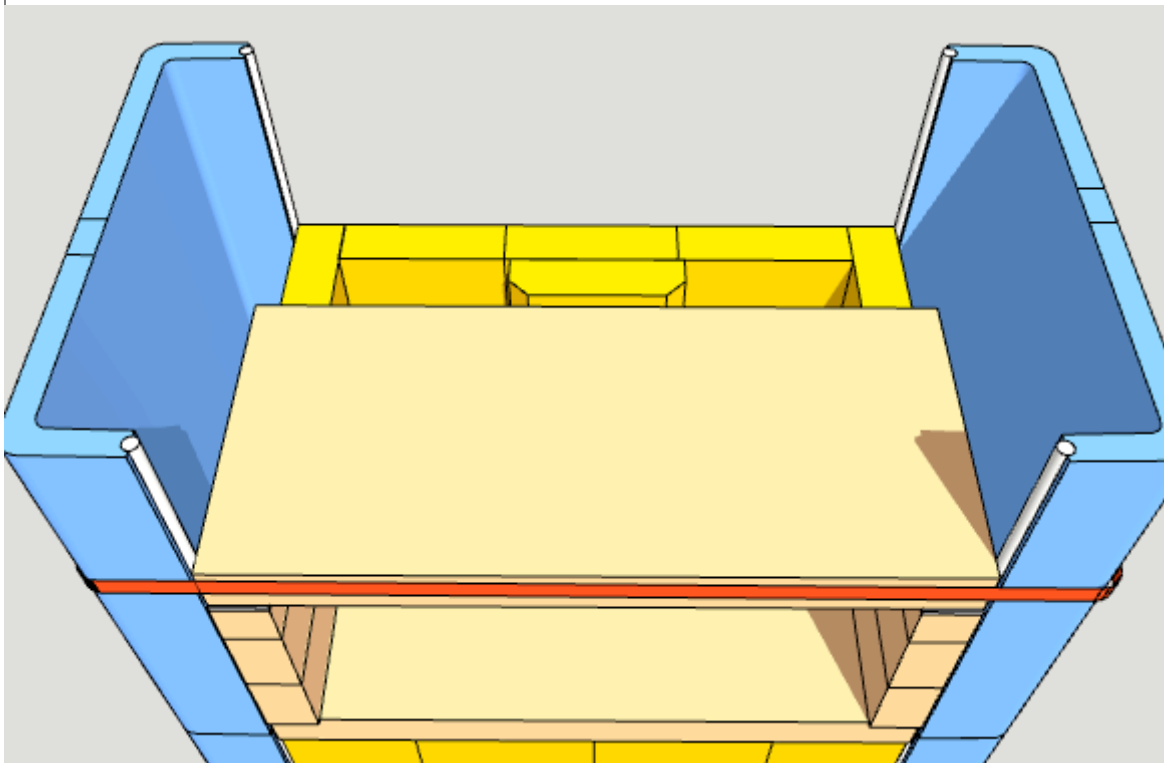

Install upper channels onto a refractory mortar bed.

Clean up any mortar squeezeout inside the channel.

The channels are marked with an arrow indicating the "up" direction.

Add the second temporary strap to stabilize the channels.

Build the transition piece at the rear wall.

See detail, below.

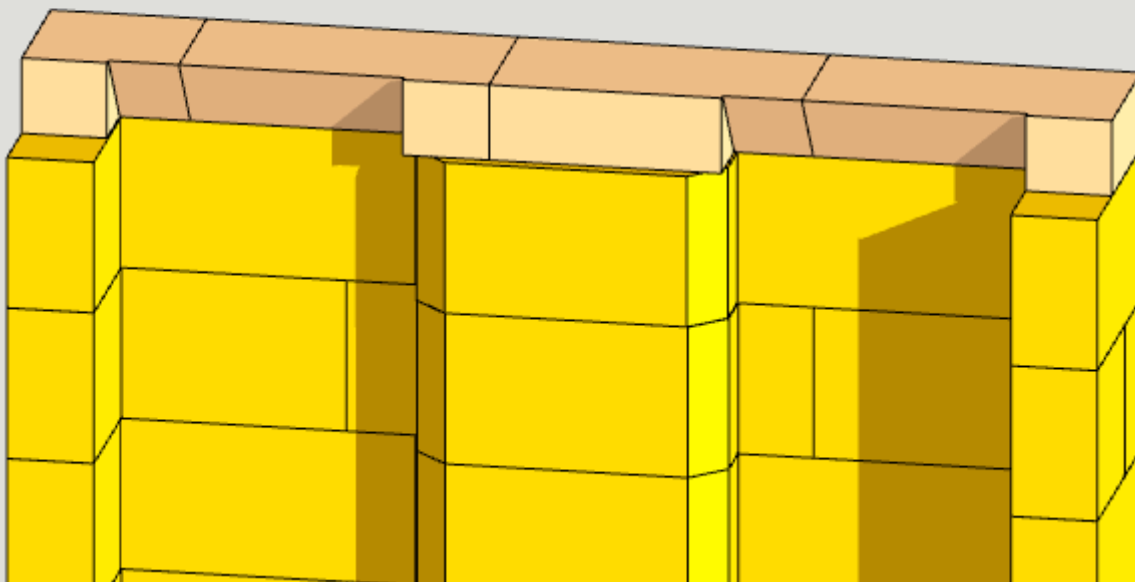
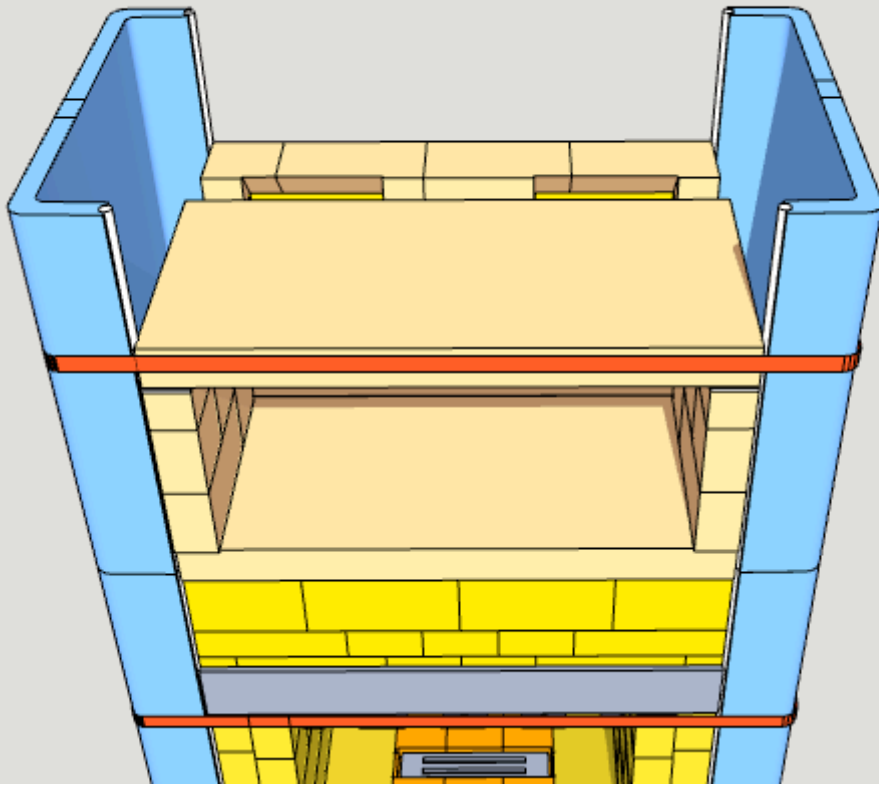

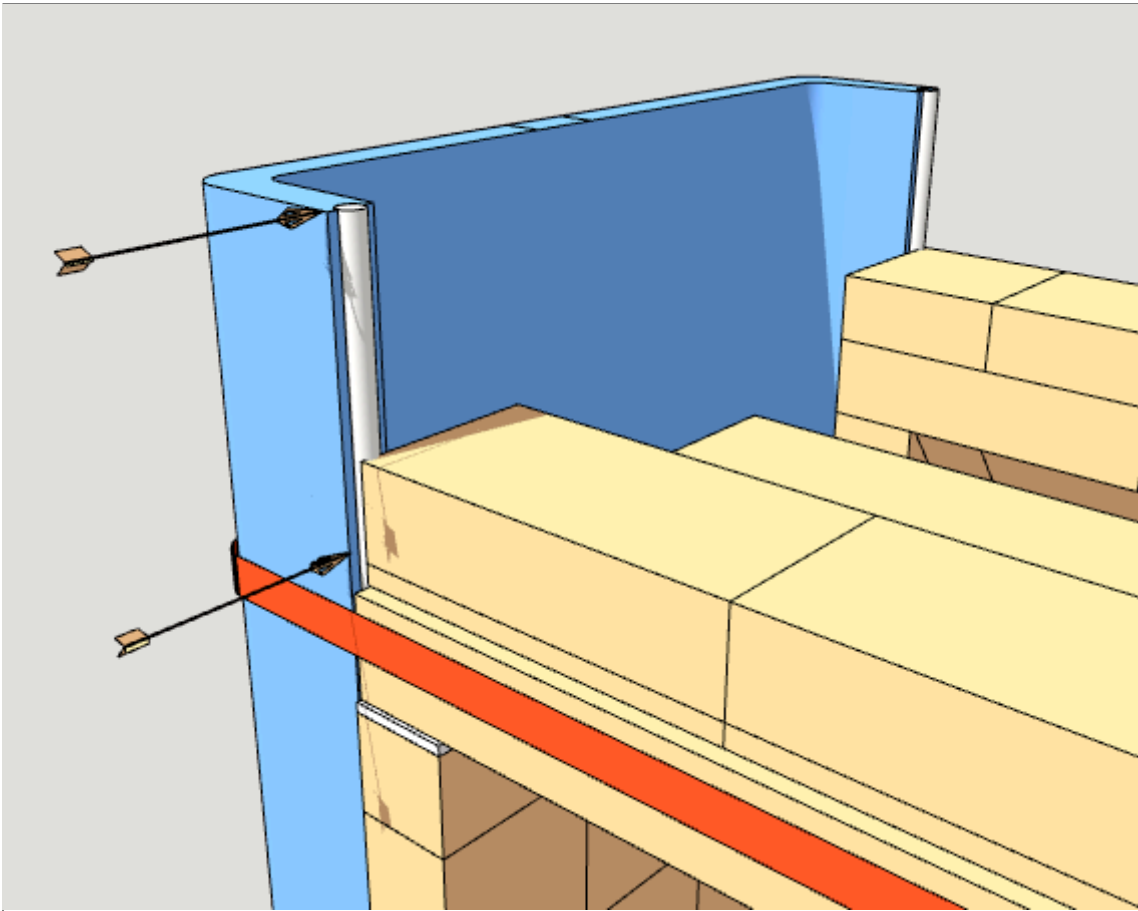

Measure the thickness of your firebricks (for example, 2-1/4", 2-5/16", etc.)

Measure from the top arrow, down to 5" + the thickness of your firebrick. For example, if your firebrick is 2-1/4", then you would measure down 7-1/4". Put a mark on the channel at this height. Repeat at the rear.

In order to come out at the right height to the top, a height adjustment is required here.

If you need more than 1-1/4" of adjustment, use firebrick splits. Otherwise, slice firebricks.

If you only need 1/2" or less, you can use ordinary brick mortar.

For 1/4" or less, use refractory mortar or refractory mortar with sand added.

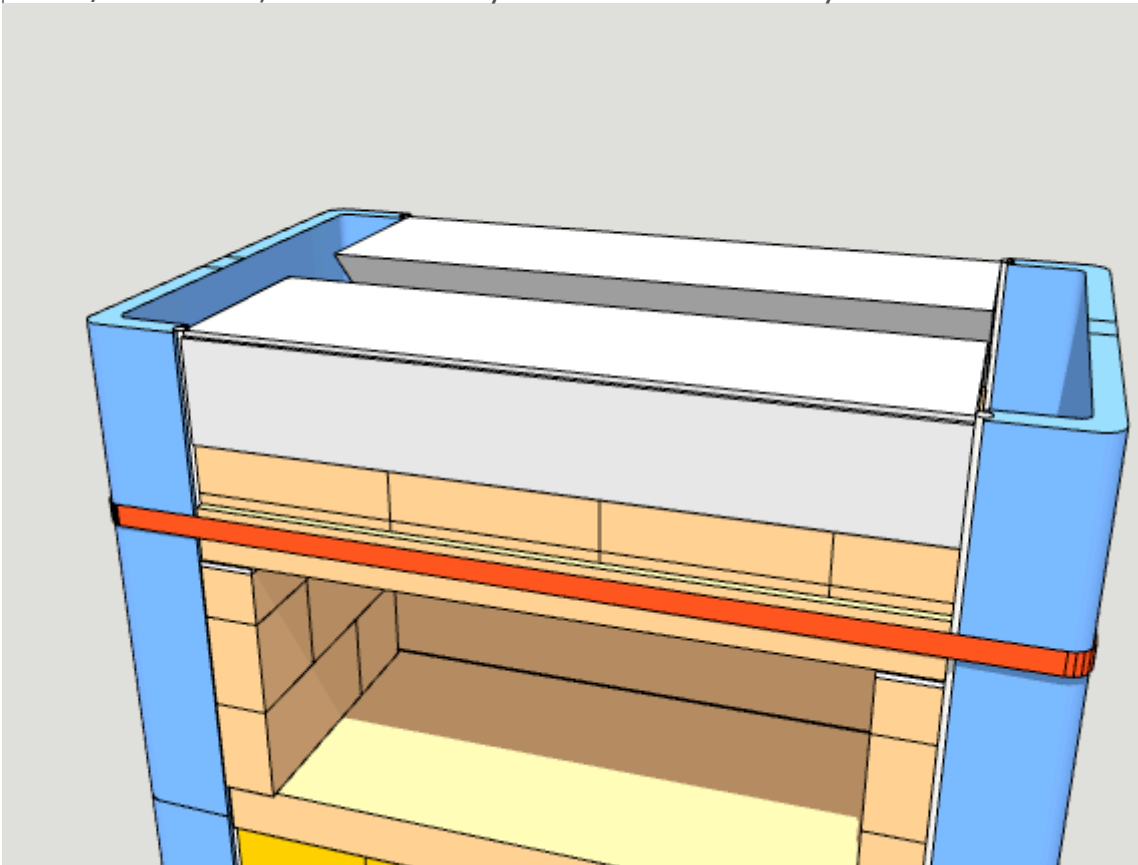

Install the precast ceiling transition pieces onto a refractory mortar bed.

Try to come out slightly higher than the channels, between 1/16" and 1/4".

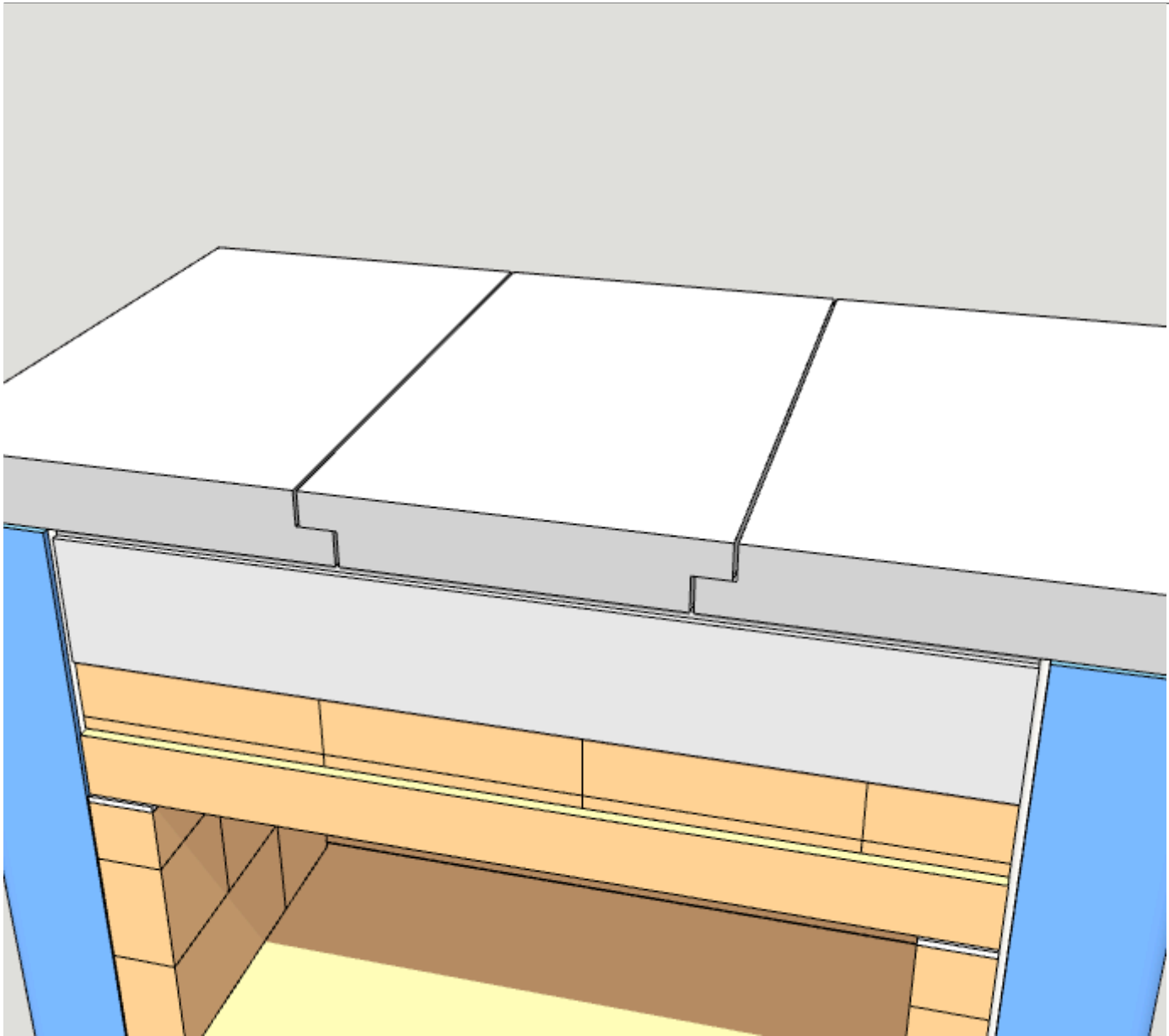

Install the precast ceiling slabs.

Use 2 people, and be careful with your staging, and plan your moves. The pieces are heavy and need to be lifted above shoulder height.

Set the pieces dry onto the core.

Leave 1/8" gap at the joints.

Seal the pieces carefully with GE silicone (provided). Fill the joints including the bottom.

Note a relief is cast into the top edge of the ceiling transition pieces, to allow for a silicone joint. Go over the joints with a metal blade, brick tie, etc. to force the silicone in and provide a permanent seal. If the joint between the ceiling and the side channels is 1/4" or less, fill with silicone. If larger, stuff with ceramic blanket (provided in a roll) first, and go over with silicone.

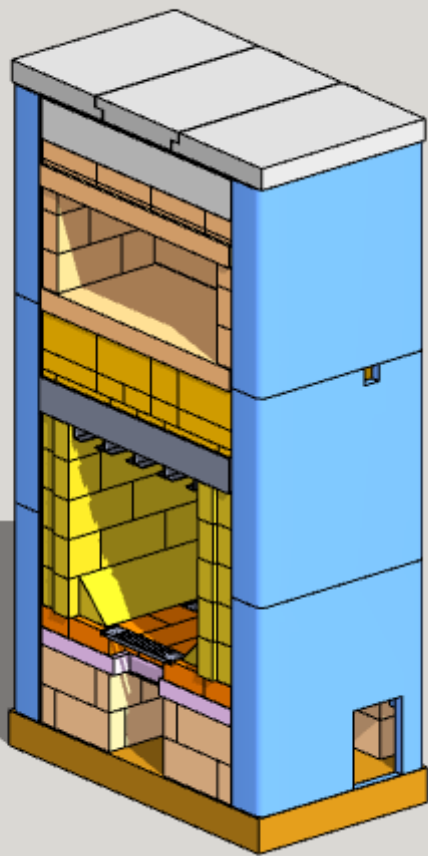

Seal the core at the fiberglass rope side channel gaskets by applying a bead of silicone where the gasket touches the firebricks.

This takes care of any small gaps, etc., that may be there. Silicone is good to 500F and remains flexible, and is suitable even for sealing fairly large gaps if you have them.

Next step is to wrap the core with a fiberglass matt slip joint. This allows the core to slide up and down inside the facing, when it heats and cools.

Make sure not to accidentally puncture the slip joint afterwards. This could lead to direct contact with the mortar slush used behind the facing and defeat the purpose.

Fiberglass matt can be messy to use. Plan your moves and handle it carefully. Use 2 people.

Put small dabs of silicone on approximately 6" centers where the white area is in the graphic

Start with the shorter of the two rolls.

With one person holding the end in place, the second person unrolls the fiberglass as they walk around the heater. Keep the top 1" above the core, and keep it flat and pat it down against the fiberglass.

Overlap the ends about 4", and trim off the excess length with scissors or tin snips.

Use the metal tape provided to secure the wrap (see next page)

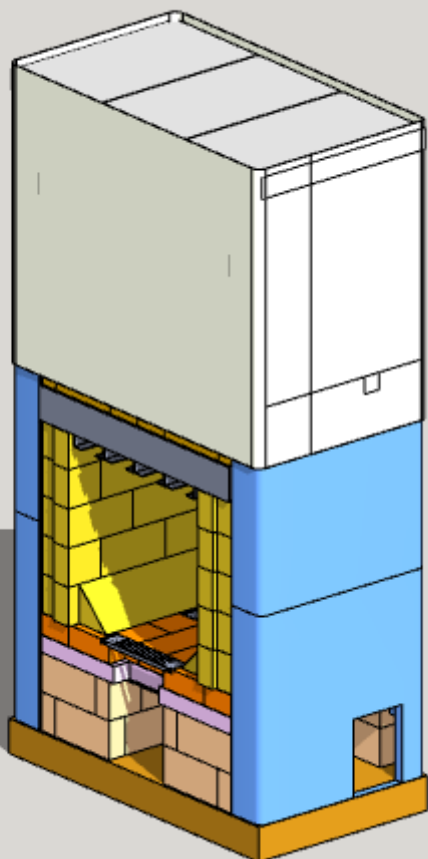

The metal tape is shown in place.

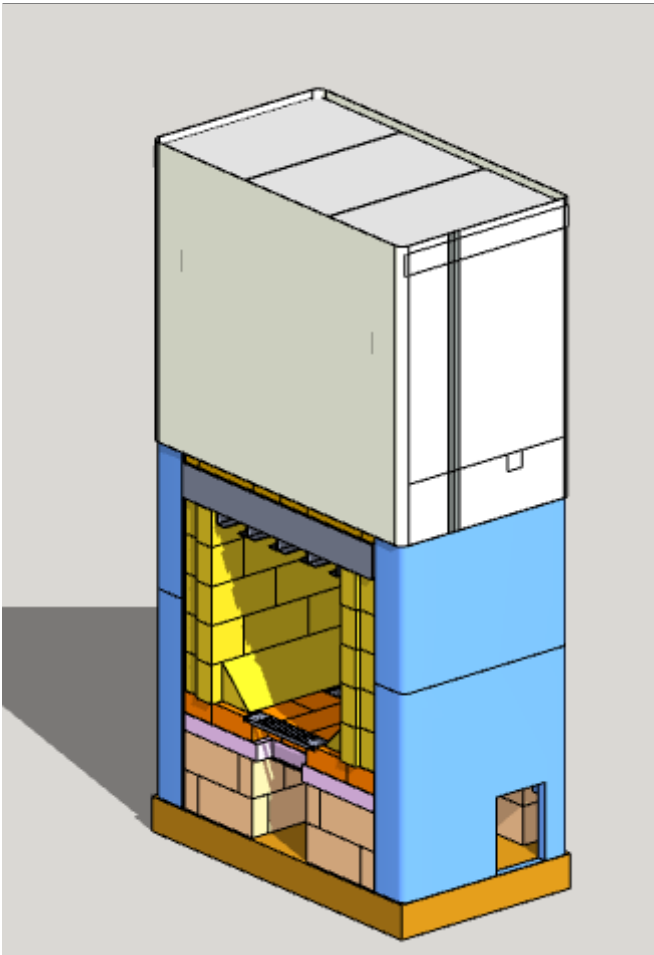

Repeat the process with the longer roll.

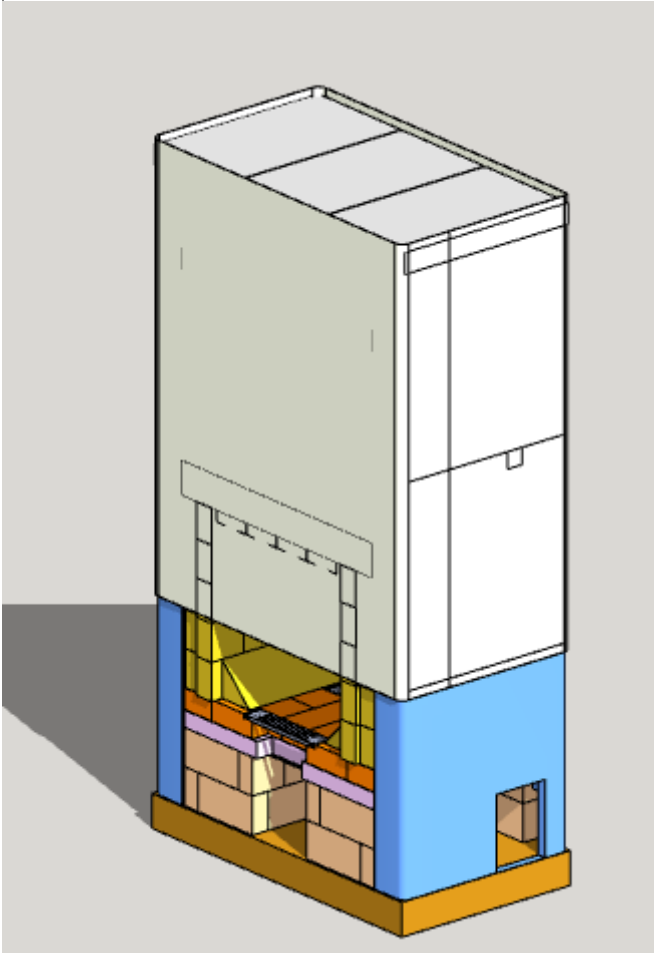

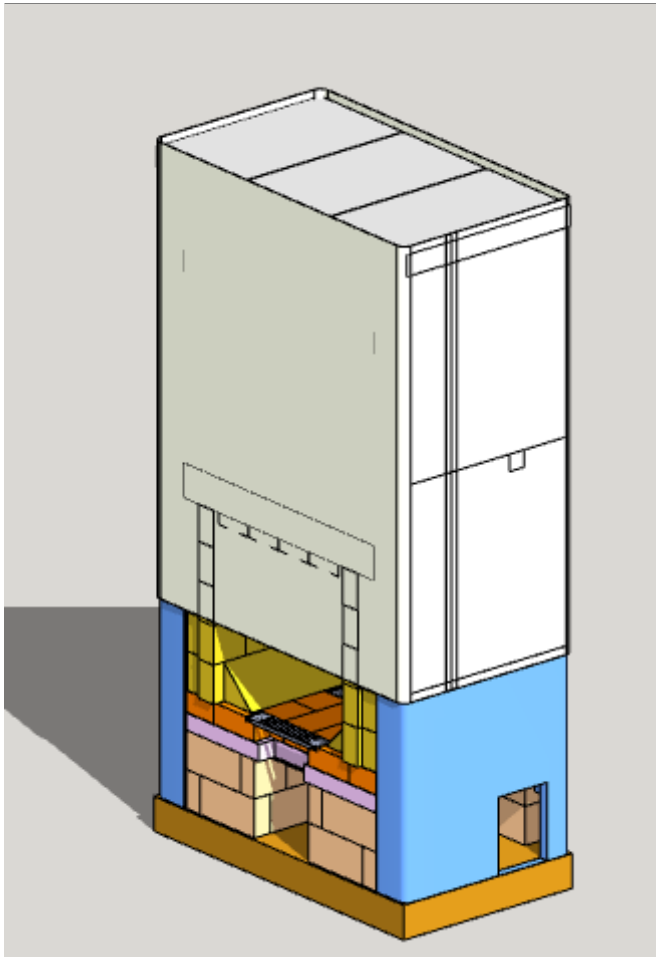

Metal tape in place on the longer piece of wrap.

Most expansion happens in the upper portion of the core, hence the doubling up of the wrap near the top.

Vertical expansion is cumulative, and there is almost none at the bottom. Therefore, no wrap is required there, and you can touch the core directly with mortar slush.

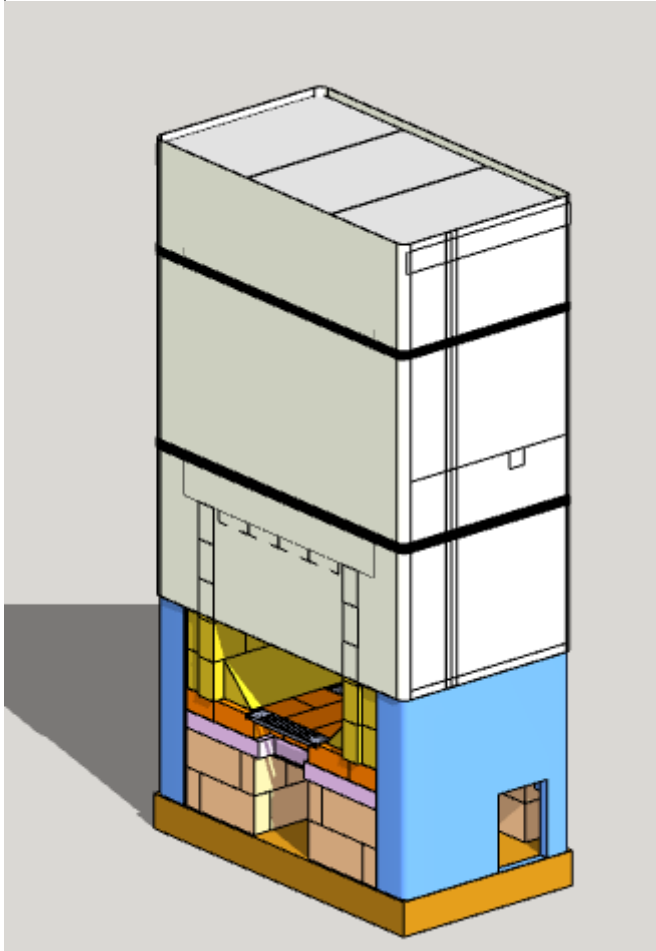

Secure the wrap with two metal straps as shown, or alternately with concrete tie wire.

See next page for location of the straps in relation to the openings.

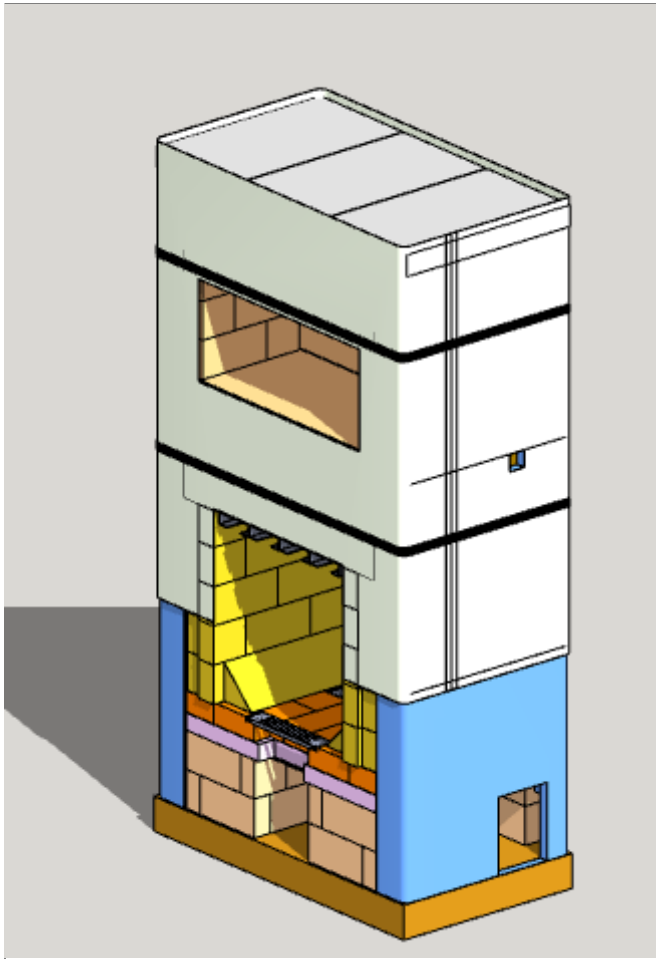

Using a utility knife with a fresh blade, trim around the openings as shown.

Make sure to trim around the 2" x 2" bypass opening also, which is easy to miss.

You will have a fuzzy edge with fibers sticking out. Around the oven open, trim these off using scissors.

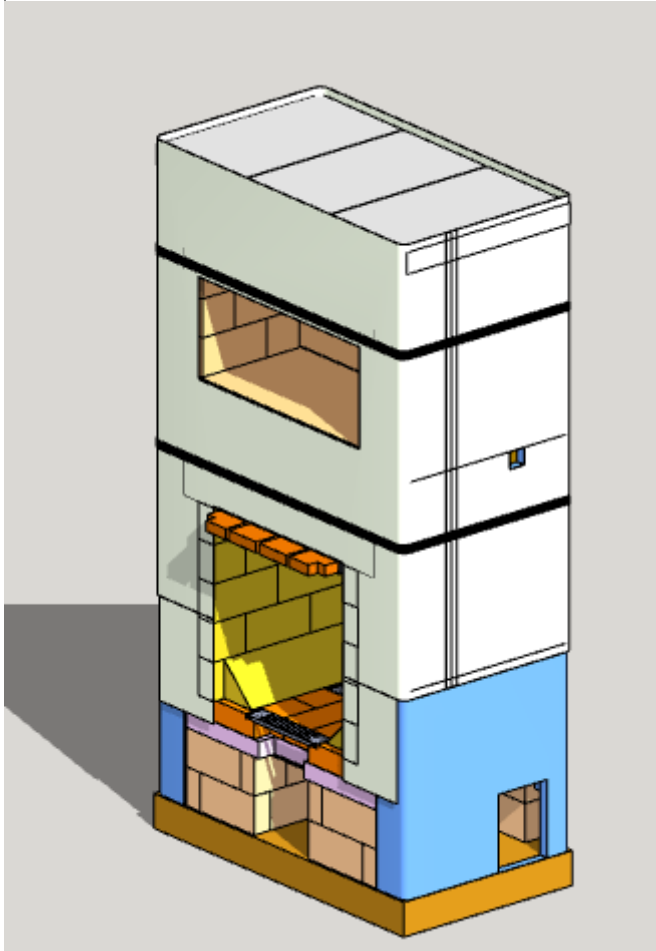

From the cutoffs, cut two pieces approx. 10" x 12", and use silicone to glue them at the bottom of the firebox front, as shown.



Heater core with fiberglass matt slip joint installed. Ready for facing. This one does not have an oven.